

Filed for record on December 20, 1974 at 8:55 A.M. in Boone Co. Mo.  
Document No. 9382 recorded in Book 11, page 98 Betty Saunders, Recorder of Deeds.

# FINAL PLAT CROSSROADS NORTH SUBDIVISION

## PLAT I

CROSSROADS NORTH SUBDIVISION  
PLAT I

LEGAL DESCRIPTION

A tract of land in the north 2 of the southeast 4 of Section 1, T48N, R13W, being further described as follows:  
Starting at the southwest corner of a survey recorded in Book 289, Page 33 of the Boone County records; thence S77°02'2"E, 385.1 feet to a point on the north right-of-way line of U. S. Interstate 70; thence along said right-of-way line, N87°03'4"E, 147.8 feet to the point of beginning; thence N 4°21'W, 731.3 feet; thence S87°01'8", 319.2 feet to a point on the west right-of-way line of U. S. Highway 63; thence with said right-of-way S25°22'E, 22.9 feet; thence continuing on said right-of-way S65°05'W, 20.0 feet; thence continuing on said right-of-way S24°55'E, 270.8 feet; thence continuing on said right-of-way S 8°52'E, 145.9 feet; thence S48°12'W, 431.0 feet to a point on the north right-of-way line of U. S. Interstate 70; thence S87°03'4"W, 72.8 feet to the point of beginning and containing 5.29 acres.

I hereby certify that the above description and attached plat correctly portrays a survey made under my direction.

James V. Patchett  
James V. Patchett, MRLS 1117

Subscribed and sworn to before, a Notary Public, in and for Boone County, Missouri, this 23<sup>rd</sup> day of February, 1974.

Bill R. Crockett  
Bill R. Crockett, Notary Public

My commission expires October 30, 1975.

Know all men by these presents:

That Land III, Ltd., a Missouri corporation, and Highland Inns Corporation, a Tennessee corporation, are the sole owners of the above described tract of land and have caused said tract of land to be surveyed, subdivided, and platted as shown on the attached plat, the street designated as Vandiver Drive is hereby dedicated to public use forever in the place shown on the plat. Easements for utilities are hereby dedicated to public use forever in the places shown on the plat.

The above description and attached plat shall hereafter be known as Crossroads North, Plat No. 1.

In witness whereof, Highland Inns Corporation has caused these presents to be signed by its proper officers and its corporate seal to be hereby affixed.

Walter Lee Shelton, Jr. Agnes D. Kyle  
Walter Lee Shelton, Jr., President Agnes D. Kyle, Secretary

On this 20 day of February, 1974, before me personally appeared Walter Lee Shelton, Jr., President and Agnes D. Kyle, Secretary, to me personally known, who by me, duly sworn, did say that they are the respective officers as stated above, of Highland Inns Corporation, and that the seal affixed to the foregoing instrument is the corporate seal of said corporation and by the authority of its Board of Directors, said Walter Lee Shelton, Jr. and Agnes D. Kyle acknowledge said instrument to be the free act and deed of said corporation. In witness whereof, I have hereunto set my hand and affixed my seal on the day and year first above written.

Patricia Greer  
Notary Public - PATRICIA GREER

My commission expires October 16, 1975.

In witness whereof, Land III, Ltd. has caused these presents to be signed by its proper officers and its corporate seal to be hereby affixed.

Raul J. Walters H. P. Gary Sprenger  
Raul J. Walters, President H. P. Gary Sprenger, Secretary

On this 13<sup>th</sup> day of February, 1974, before me personally appeared Raul J. Walters, President and H. P. Gary Sprenger, Secretary, to me personally known, who by me, duly sworn, did say that they are the respective officers as stated above, of Land III, Ltd., and that the seal affixed to the foregoing instrument is the corporate seal of said corporation and by the authority of its Board of Directors, said Raul J. Walters and H. P. Gary Sprenger acknowledge said instrument to be the free act and deed of said corporation. In witness whereof, I have hereunto set my hand and affixed my seal on the day and year first above written.

Lavon R. Childers  
Notary Public - LAVON R. CHILDERS

My commission expires December 22, 1974.

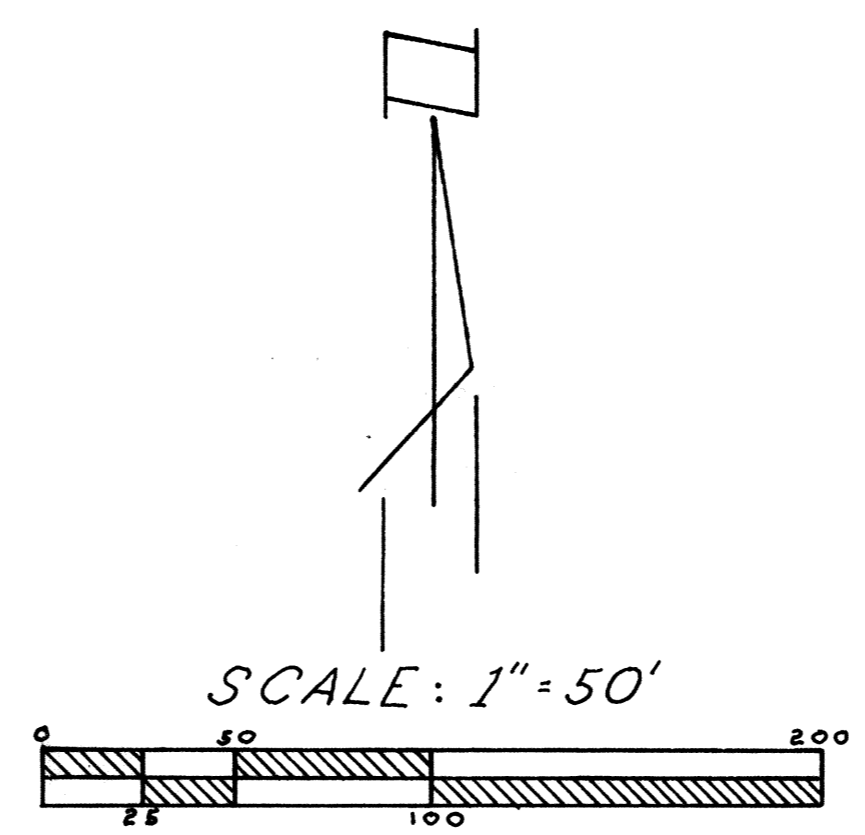

NOTE:  
△ INDICATES R/W MARKER

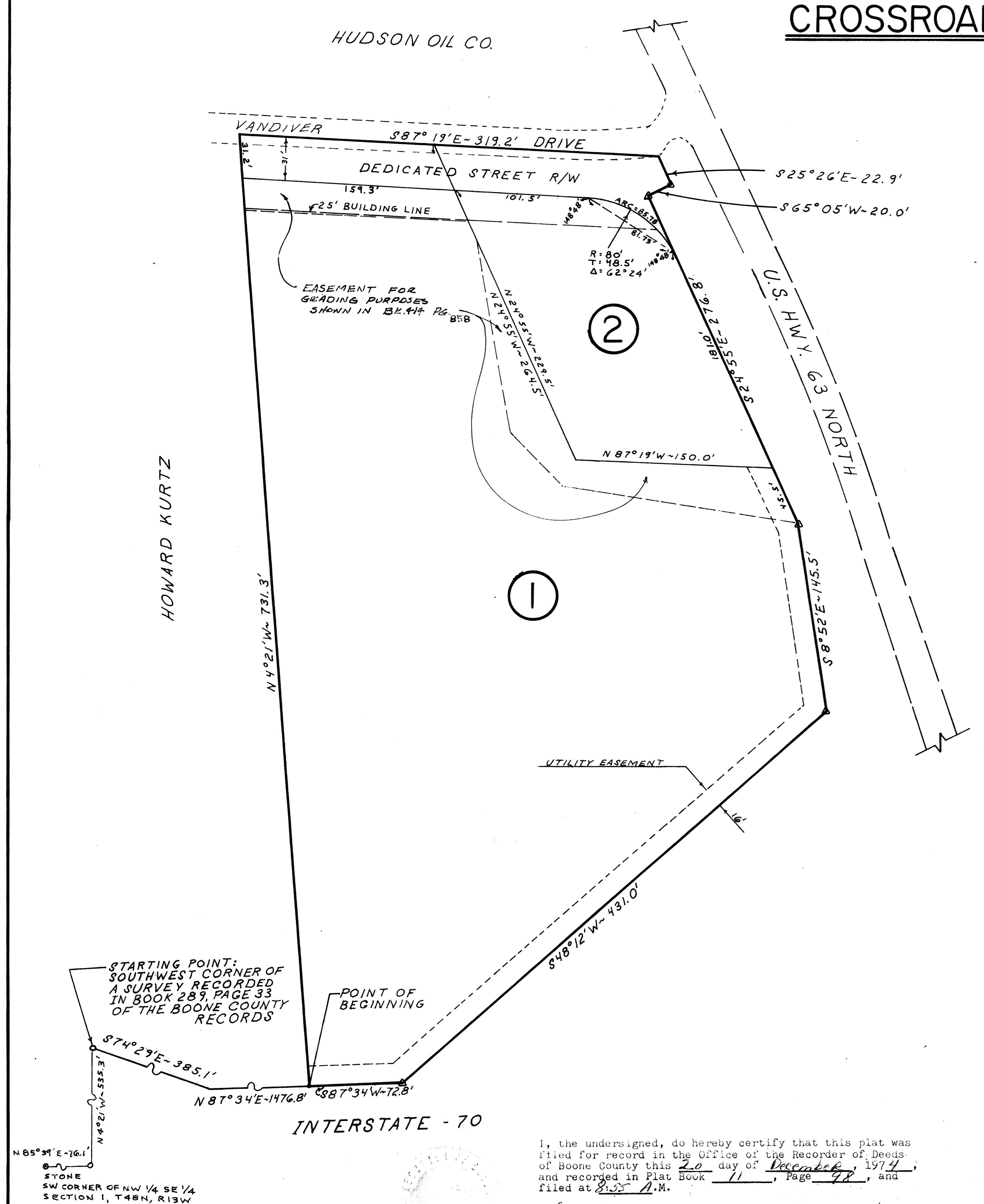

C-49

I, the undersigned, do hereby certify that this plat was filed for record in the Office of the Recorder of Deeds of Boone County this 20 day of December, 1974, and recorded in Plat Book 11, Page 98, and filed at 8:55 A.M.

Betty Saunders Paula Marie Siegel  
Recorder of Deeds Deputy Recorder of Deeds

Accepted by ordinance of the City Council, this 16<sup>th</sup> day of DECEMBER, 1974, provided, however, that the City accepts no obligation to maintain any of the streets dedicated on this plat until they are approved to meet the City's minimum street specifications.

Sam Anderson Glenn Wood  
Mayor, City of Columbia City Clerk