

GENERAL NOTES

- ALL LAND CONTAINED WITHIN THIS PRELIMINARY PLAT IS SUBJECT TO A DEVELOPMENT AGREEMENT CORRESPONDING TO THE ANNEXATION AND ZONING OF THE LAND, BETWEEN THE OWNER AND THE CITY OF COLUMBIA, AND APPROVED BY THE CITY OF COLUMBIA COUNCIL AND RECORDED IN BOOK 4423, PAGE 41 OF THE BOONE COUNTY RECORDS.
- THERE ARE NO BUILDINGS CURRENTLY ON THIS SITE.
- LOT NUMBERS ARE FOR INVENTORY PURPOSES ONLY.
- PUBLIC WATER SUPPLY DISTRICT NO. 9 (PWS# #9) HAS A 12" WATER MAIN ON THE NORTH SIDE OF ST. CHARLES ROAD AND WEST SIDE OF BATTLE AVENUE TO SPARTAN DRIVE, FROM SPARTAN DRIVE NORTH, ALONG THE WEST SIDE OF BATTLE, IS AN 8" WATER MAIN THAT TERMINATES NEAR THE NORTH PROPERTY LINE.
- THE PROPOSED WATER EXTENSIONS TO BE BUILT WITH DEVELOPMENT OF THIS PRELIMINARY PLAT WILL REQUIRE A WATER STUDY TO BE PERFORMED AT THE TIME OF FINAL PLATTING AND WATERLINE LAYOUT DESIGN FOR PWS# #9 AND TO VERIFY TO CULF FLOW REQUIREMENTS MEET CITY ORDINANCE. WATER MAIN EXTENSIONS MAY BE DESIGNED IN PHASES CORRESPONDING TO THE FINAL PLATTING OF THE PROPERTY GIVEN THAT REQUIRED FLOWS AND WATER QUALITY ARE MAINTAINED. WATER MAINS SHALL COMPLY WITH THE REQUIREMENTS OF PWS# #9.

LEGEND

MH ○	EXISTING SANITARY MANHOLE
MH ●	PROPOSED SANITARY MANHOLE
CO ○	EXISTING SANITARY CLEANOUT
CO ●	PROPOSED SANITARY CLEANOUT
FH ○	EXISTING FIRE HYDRANT
FH ●	PROPOSED FIRE HYDRANT
ET	EXISTING ELECTRIC TRANSFORMER
ET	EXISTING TELEPHONE BOX
UT	EXISTING UTILITY POLE
WV X	EXISTING WATER VALVE
2K	PROPOSED STREET GRADE
HP	PROPOSED HIGH POINT (CONCEP. ONLY)
X	EXISTING FENCE
UE	EXISTING UNDERGROUND ELECTRIC
OE	EXISTING OVER-HEAD ELECTRIC
G	EXISTING GAS
S	EXISTING SANITARY
S	PROPOSED SANITARY
W	EXISTING WATER
W	PROPOSED WATER
SS	EXISTING STORM SEWER
SS	PROPOSED STORM SEWER
CTV	EXISTING CABLE TELEVISION
FE	EXISTING FLOWLINE (FE)
TR	EXISTING TREETRINE
PT	APPROXIMATE PRESERVED TREETRINE
CON	EXISTING CONTOUR
CL	CITY OF COLUMBIA CORPORATE LIMITS

- FINAL CONSTRUCTION PLANS SHALL COORDINATE WATER METER/ELECTRIC METER AND ACCESS RELOCATION IF AND AS NECESSARY FOR THE TRACT CURRENTLY OWNED BY THE CHARLES MERIDETH TRUST.
- BOONE ELECTRIC SERVICE TO THIS PROPERTY CURRENTLY CONSISTS OF AN OVERHEAD THREE PHASE LINE RUNNING ON THE NORTH SIDE OF ST. CHARLES ROAD AND OVERHEAD THREE PHASE ELECTRIC ALONG THE EAST SIDE OF BATTLE AVENUE. BOONE ELECTRIC WILL PROVIDE ELECTRIC SERVICE ADJACENT TO ALL PROPOSED STREETS. ELECTRIC DISTRIBUTION DESIGN BY BOONE ELECTRIC. STREET LIGHTING BY BOONE ELECTRIC.
- THE ROADWAYS SHOWN ON THIS PRELIMINARY PLAT ARE INTENDED TO CONFORM WITH THE CATSO THOROUGHFARE PLAN AS WELL AS RECOMMENDATIONS PROPOSED FROM THE CRAWFORD, BUNTE & BRAMMEIER (CBB) TRAFFIC STUDY COMMISSIONED BY THE BOONE COUNTY COMMISSION, DATED OCTOBER 2012.
- SANITARY SEWER SERVICE TO THIS PLAT WILL BE PROVIDED BY OFF-SITE CONNECTION TO CITY OF COLUMBIA GRINDSTONE TRUNK GRAVITY SEWER MAIN, AS SHOWN ON THE PLAT. LOT 305, EAST OF THE CREEK, MAY CONNECT TO BCRSD MAINTAINED GRAVITY SEWER MAIN IN FRANK STANTON SUBDIVISION, THE BCRSD LINE EVENTUALLY DRAINS TO THE CITY OF COLUMBIA PUBLIC SANITARY SEWER NETWORK.
- ALL PUBLIC GRAVITY SANITARY SEWER EXTENSIONS SHALL BE A MINIMUM OF 6" DIAMETER. SEWERS NOT CONSTRUCTED ALONG FRONTS OF LOTS TO BE LOCATED WITHIN MINIMUM 16-FOOT WIDE EASEMENTS OR EASEMENTS EQUAL TO THE DEPTH OF THE SEWER IF SEWER DEPTH IS GREATER THAN 16 FEET. PUBLIC SANITARY SEWERS SHALL BE BUILT IN COMPLIANCE WITH CITY OF COLUMBIA STANDARDS AND SPECIFICATIONS.
- ALL R-1 LOTS SHALL HAVE A MINIMUM 25' FRONT BUILDING SETBACKS UNLESS OTHERWISE NOTED. PLANNED DISTRICT LOTS SHALL HAVE BUILDING SETBACKS IN COMPLIANCE WITH ITS ZONING.
- A MINIMUM 10' UTILITY EASEMENT SHALL BE PROVIDED ADJACENT TO ALL PROPOSED STREETS SHOWN UNLESS OTHERWISE NOTED. UTILITY EASEMENT WIDTHS WILL BE SUBJECT TO REVIEW AND APPROVAL OF ALL APPLICABLE UTILITY SERVICE PROVIDERS. AN EXISTING 20" UTILITY EASEMENT IS LOCATED ADJACENT TO BOTH SIDES OF BATTLE AVENUE. AN ADDITIONAL 15' ELECTRIC EASEMENT GRANTED TO BOONE ELECTRIC EXISTS ALONG THE EAST SIDE OF BATTLE AVENUE. AN EXISTING 25" UTILITY EASEMENT IS LOCATED ADJACENT TO THE NORTH SIDE OF ST. CHARLES ROAD.
- THIS LINE REPRESENTS THE BOUNDARY-LINE OF LOT 101 AS SHOWN ON SOMERSET VILLAGE PLAT 1 FINAL PLAT RECORDED IN PLAT BOOK 46, PAGE 44.
- COMMON AREA LOTS C401, C402, C403, C404, C405, C406, C407, AND C408 ARE NOT FOR RESIDENTIAL DEVELOPMENT AND WILL BE TRANSFERRED TO A HOME OWNERS ASSOCIATION FOR MAINTENANCE. NUMBER, SIZE, CONFIGURATION, AND LOCATION OF COMMON LOTS SUBJECT TO FINAL DESIGN. COMMON LOTS MAY BE USED FOR LANDSCAPING, GREENSPACE, STORMWATER BMP'S, SIGNS AS ALLOWED BY ZONING REGULATIONS, AND OTHER NEIGHBORHOOD AMENITIES. NECESSARY EASEMENTS SHALL BE DEDICATED AT TIME OF FINAL PLATTING.
- NATURAL GAS DISTRIBUTION TO BE DESIGNED BY AMEREN.
- DRAINAGE EASEMENTS SHALL HAVE A MINIMUM WIDTH OF 16' OR WIDER AS NEEDED AND SHALL BE PROVIDED TO CONTAIN THE RUNOFF IN CONCENTRATED FLOWS FROM A 100-YEAR RAINFALL EVENT.
- STREET ALIGNMENTS MAY BE ALTERED WITH FINAL DESIGN AS NEEDED TO MAXIMIZE SIGHT DISTANCE, AND MINIMIZE GRADING DISTURBANCE AT ENGINEERS DISCRETION.
- STREET GRADES, STORM SEWER PIPE AND STORM INLETS, AND SANITARY SEWER LOCATIONS SHOWN ARE CONCEPTUAL IN NATURE AND WILL BE REFINED WITH THE FINAL DESIGN.
- ALL RESIDENTIAL STREETS MAY BE ALLOWED TO HAVE ALTERNATE TYPICAL CROSS SECTION TO ALLOW FOR TREES TO BE PLANTED BETWEEN THE SIDEWALK AND PAVEMENT. SIDEWALK TO BE LOCATED IN A 6-FOOT SIDEWALK EASEMENT ADJOINING THE STREET RIGHT-OF-WAY. TYPICAL CROSS SECTIONS SHOWN ON SHEET 2 AND 3.
- ACCESS ROAD ADJACENT TO SPARTAN DR AND BATTLE AVE MAY HAVE ALTERNATE CROSS SECTIONS AS SHOWN ON SHEET 2 TO ACCOMMODATE STREET TREES AND ELIMINATE REDUNDANT SIDEWALK.

PRELIMINARY PLAT
SOMERSET VILLAGE,
PLAT NO. 2

LOTS 101 AND 102 OF SOMERSET VILLAGE PLAT 1; LOT 203 OF SOMERSET VILLAGE PLAT 2; AND PART OF THE EAST 1/2 OF SECTION 2, T48N, R12W, BOONE COUNTY, MISSOURI
NOVEMBER 16, 2015

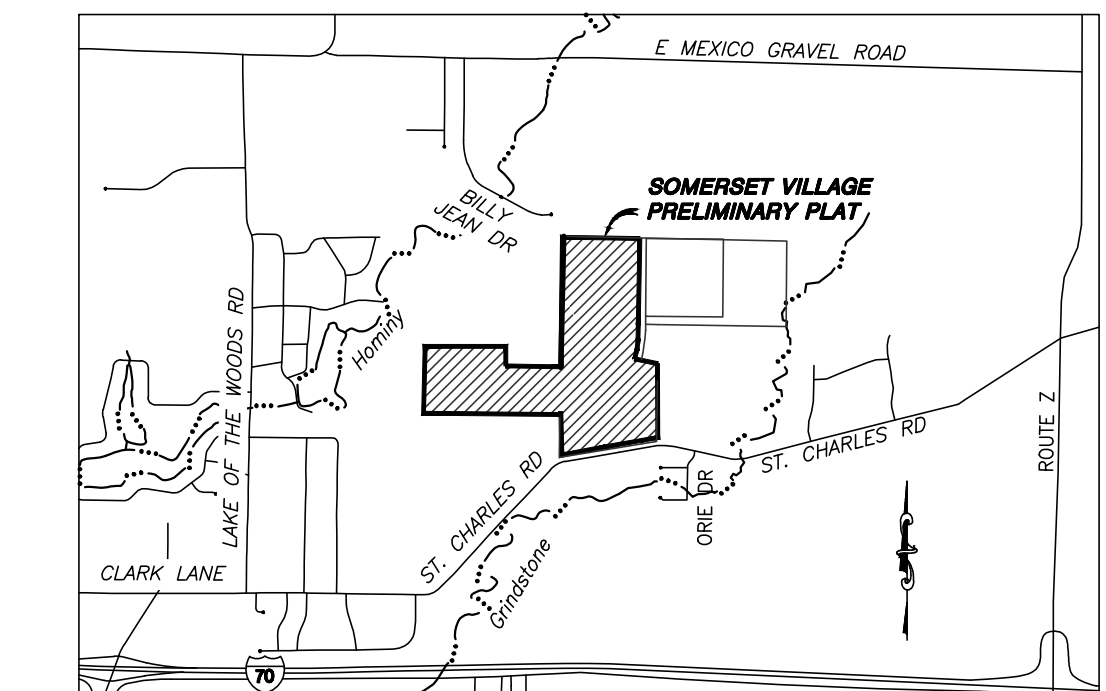

OWNER/DEVELOPER
ST. CHARLES ROAD DEVELOPMENT, LLC
C/O ROB WOLVERTON
2504 ST. REGIS CT.
COLUMBIA, MO 65203
(573) 999-6551

SITE DATA
ACREAGE: 127.81 ACRES
SECTION-TOWNSHIP-RANGE: 1-48-12 & 2-48-12
PROPOSED ZONING:
95.45 ACRES R-1, SINGLE FAMILY RESIDENTIAL - (211 SINGLE FAMILY LOTS, 8 COMMON LOTS AND 2 CITY TRANSFER LOTS SHOWN)
8.47 ACRES O-P WITH 40 MAX PUD UNITS - (LOT 302)
7.70 ACRES O-P WITH MAX PUD-18 DENSITY, - (LOT 303)
16.19 ACRES C-P - (LOTS 304 AND 305)

PHASING NOTES

- DEVELOPMENT WEST OF BATTLE AVENUE AND SOUTH OF SPARTAN DRIVE IS LIMITED TO NO MORE THAN 100 LOTS BEFORE A SECONDARY ACCESS IS REQUIRED ONTO BATTLE AVENUE.
- THIS DEVELOPMENT SHALL BE ALLOWED TO BE CONSTRUCTED IN MULTIPLE PHASES. THE PHASES OF CONSTRUCTION MAY BE BUILT OVER AN UNSPECIFIED NUMBER OF YEARS.
- TOTAL NUMBER OF LOTS AND PHASES MAY BE ADJUSTED AS NECESSARY AND AT DEVELOPER'S DISCRETION TO FACILITATE GRADING AND INFRASTRUCTURE IMPROVEMENTS AS LONG AS GENERAL CONFORMANCE TO THE PRELIMINARY PLAT AND R-1 ZONING ARE MAINTAINED.

STREAM BUFFER STATEMENT

- THIS TRACT IS REGULATED BY THE STREAM BUFFER REQUIREMENTS IN SECTION 12A-30, ARTICLE X OF THE CITY OF COLUMBIA CODE OF ORDINANCES AS SHOWN BY THE MILLERSBURG USGS QUADRANGLE.
- PORTIONS OF THE STREAM BUFFER HAVE BEEN SHOWN ON THE RECORDED SOMERSET VILLAGE PLAT 1 AND IS PRESUMED TO BE IN COMPLIANCE AS PREVIOUSLY DETERMINED.

TREE PRESERVATION NOTE:

- ALL LAND WITHIN THIS SOMERSET VILLAGE PRELIMINARY PLAT SHALL BE SUBJECT TO SECTION 12A-49 OF THE CITY OF COLUMBIA CODE OF ORDINANCES.
- PRIOR TO ANY LAND DISTURBANCE OR FINAL PLATTING OF ANY PART OF THIS TRACT WEST OF BATTLE AVENUE A TREE PRESERVATION PLAN SHALL BE APPROVED BY THE CITY ARBORIST FOR THE ENTIRE TRACT. THE APPROVED TREE PRESERVATION PLAN SHALL REMAIN VALID THROUGH FUTURE PLATTING GIVEN THE PROPOSED DEVELOPMENT IS IN CONFORMANCE WITH THE APPROVED PLAN.
- THE TREE PRESERVATION PLAN MAY BE REVISED BY THE OWNER AS LONG AS THE TREE PRESERVATION REMAINS IN COMPLIANCE WITH CITY REGULATIONS AT TIME OF REVISIONS EXCEPT AS NOTED BY THE CITY ARBORIST.
- EXISTING CLIMAX FOREST AS DETERMINED BY THE CITY ARBORIST = 7.81 ACRES
MINIMUM OF 25% CLIMAX FOREST TO BE PRESERVED = 1.95 ACRES.

LEGAL DESCRIPTION

LOTS 101 AND 102 OF SOMERSET VILLAGE PLAT 1 AS RECORDED IN PLAT BOOK 46, PAGE 44, ; LOT 203 OF SOMERSET VILLAGE PLAT 2 AS RECORDED IN PLAT BOOK 46, PAGE 45; AND PART OF THE EAST 1/2 OF SECTION 2, T48N, R12W, AS DESCRIBED BY THE WARRANTY DEED RECORDED IN BOOK 3837, PAGE 91, ALL RECORDS OF BOONE COUNTY, MISSOURI AND CONTAINING 127.81 ACRES.

SHEET INDEX

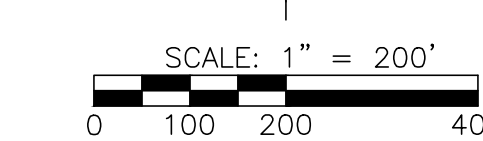
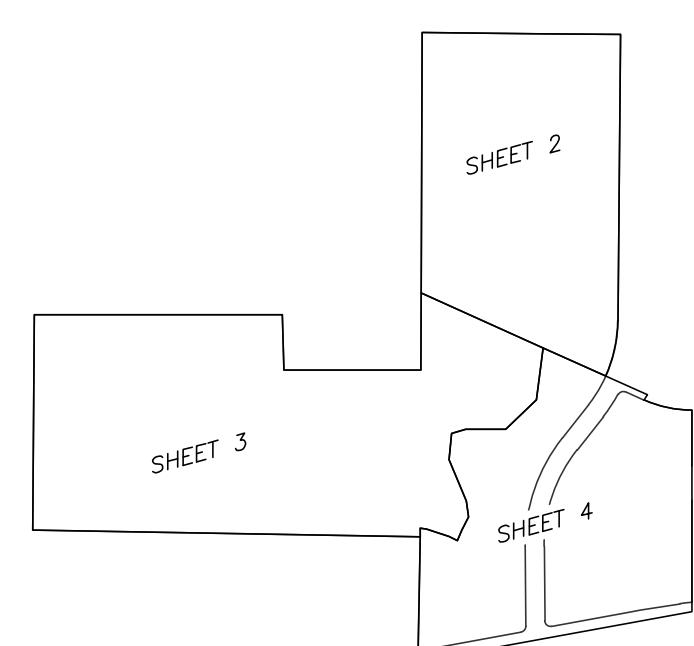

X:\Project\1ST CHARLES DEVELOPMENT CO\SOMERSET VILLAGE\DRAWINGS\Preliminary Plat City\SCDC15-10 Preliminary Plat\dwg\PRELIM PLAT SHEET 1

APPROVED BY THE CITY OF COLUMBIA PLANNING AND ZONING COMMISSION THIS _____ DAY OF _____, 2016.
STEPHEN REICHLIN, CHAIRMAN

THIS DOCUMENT HAS BEEN ELECTRONICALLY SIGNED, SEALED AND DATED

A CIVIL GROUP
CIVIL ENGINEERING • PLANNING • SURVEYING
3401 BROADWAY BUSINESS PARK COURT
SUITE 105
COLUMBIA, MO 65203
PH: (573) 817-5750, FAX: (573) 817-1677
MISSOURI CERTIFICATE OF AUTHORITY: 2001006115

PRELIMINARY PLAT
**SOMERSET VILLAGE,
 PLAT NO. 2**

K:\Project\1st CHARLES DEVELOPMENT CO\SOMERSET VILLAGE\DRAWINGS\Preliminary Plat\CD\SCDC15-10 Preliminary Plat\CD\PRELIM PLAT SHEET 2

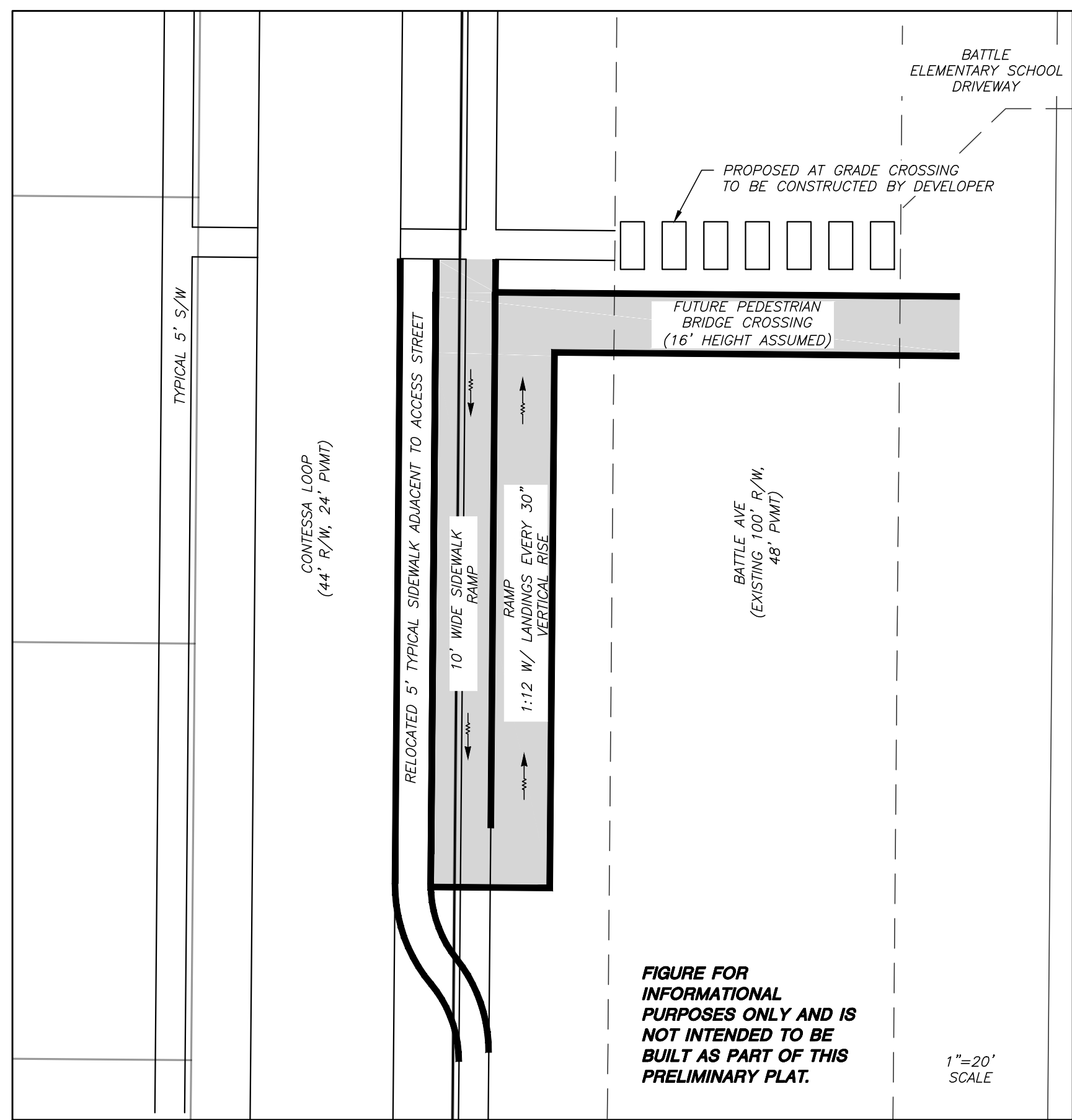

FUTURE PEDESTRIAN CROSSING

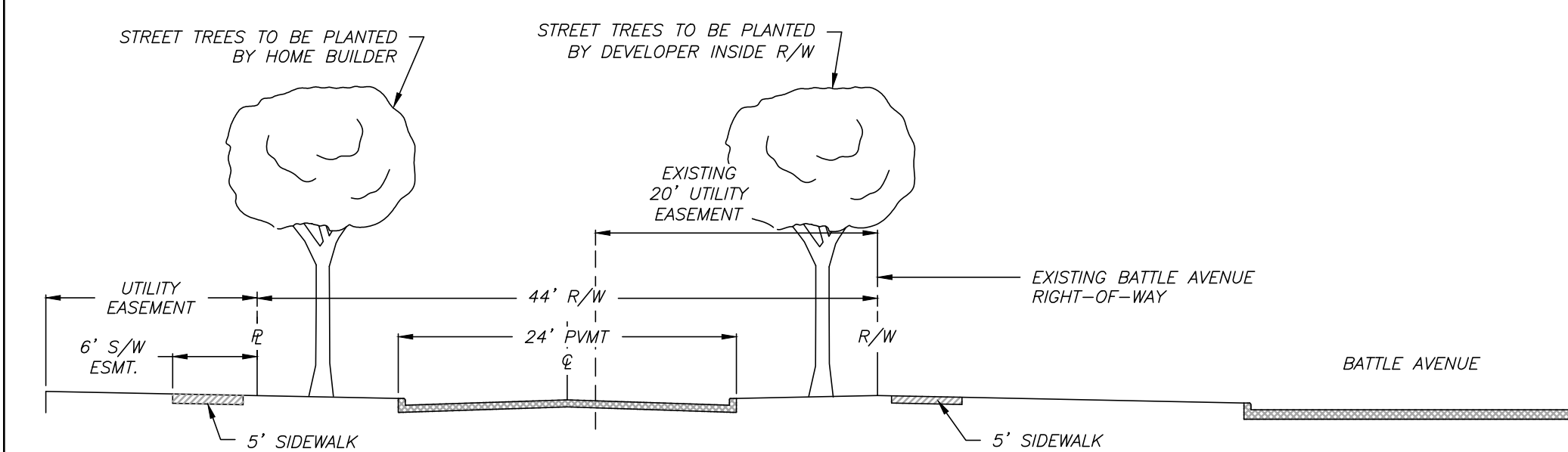

BATTLE AVENUE & ACCESS ROAD (44' R/W)

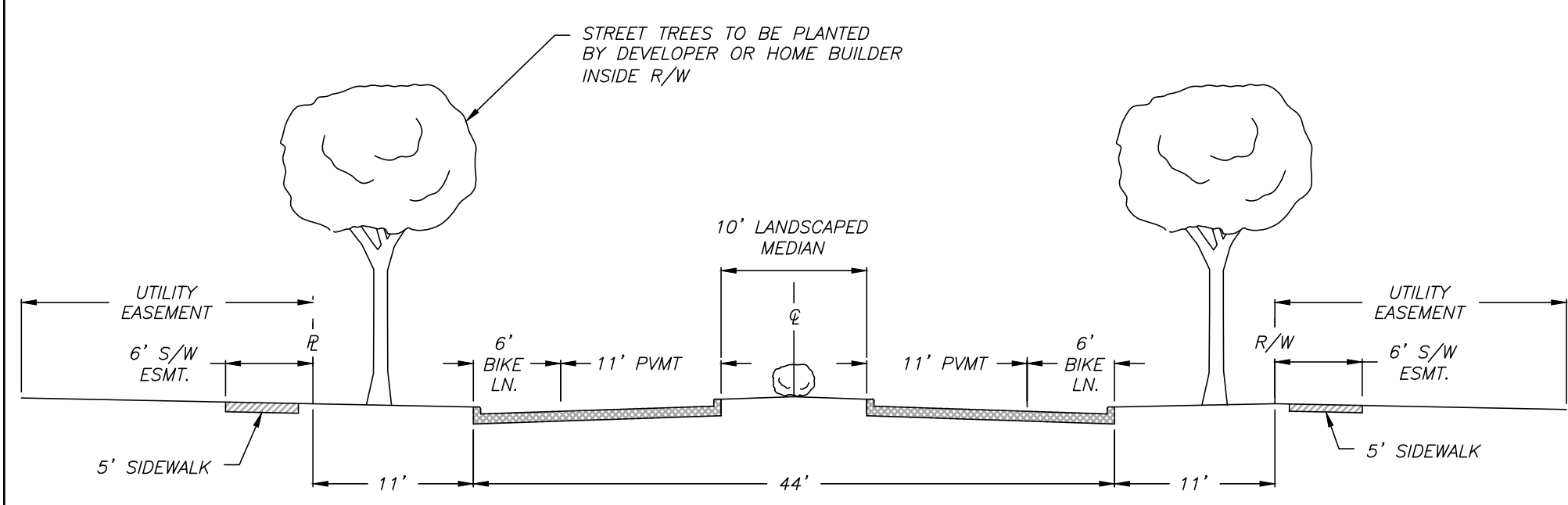

SPARTAN DRIVE (66' R/W W/ MEDIAN)

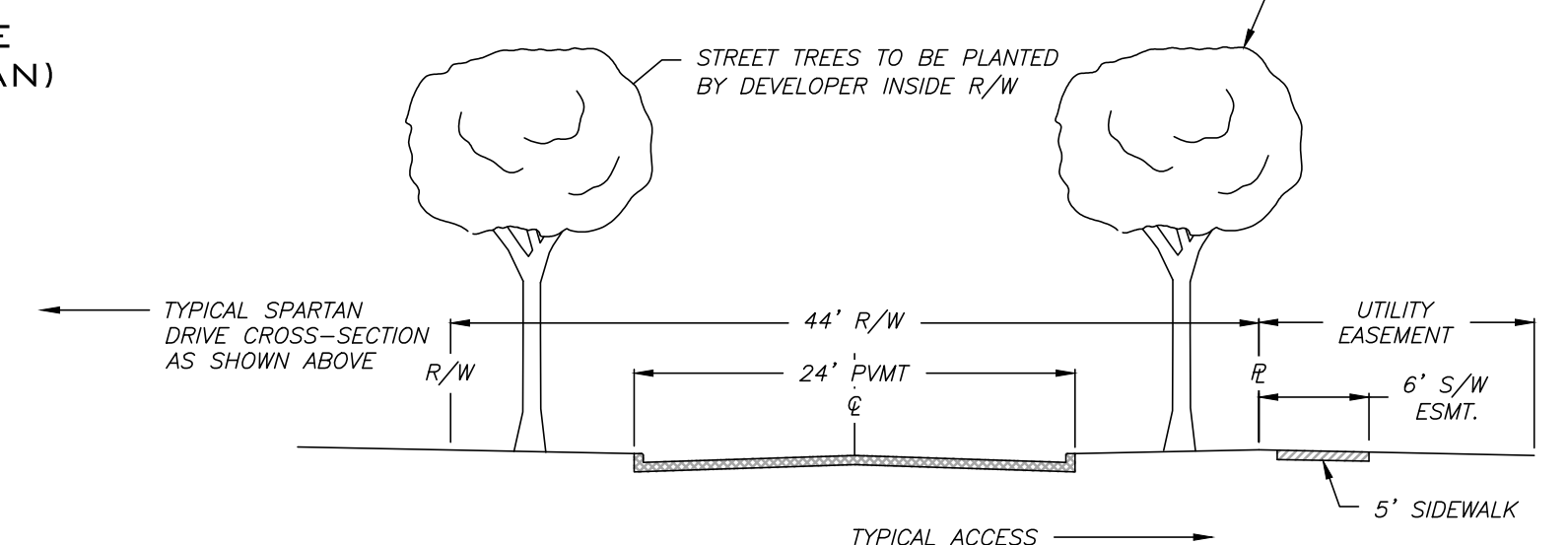

ACCESS ROAD (44' R/W)

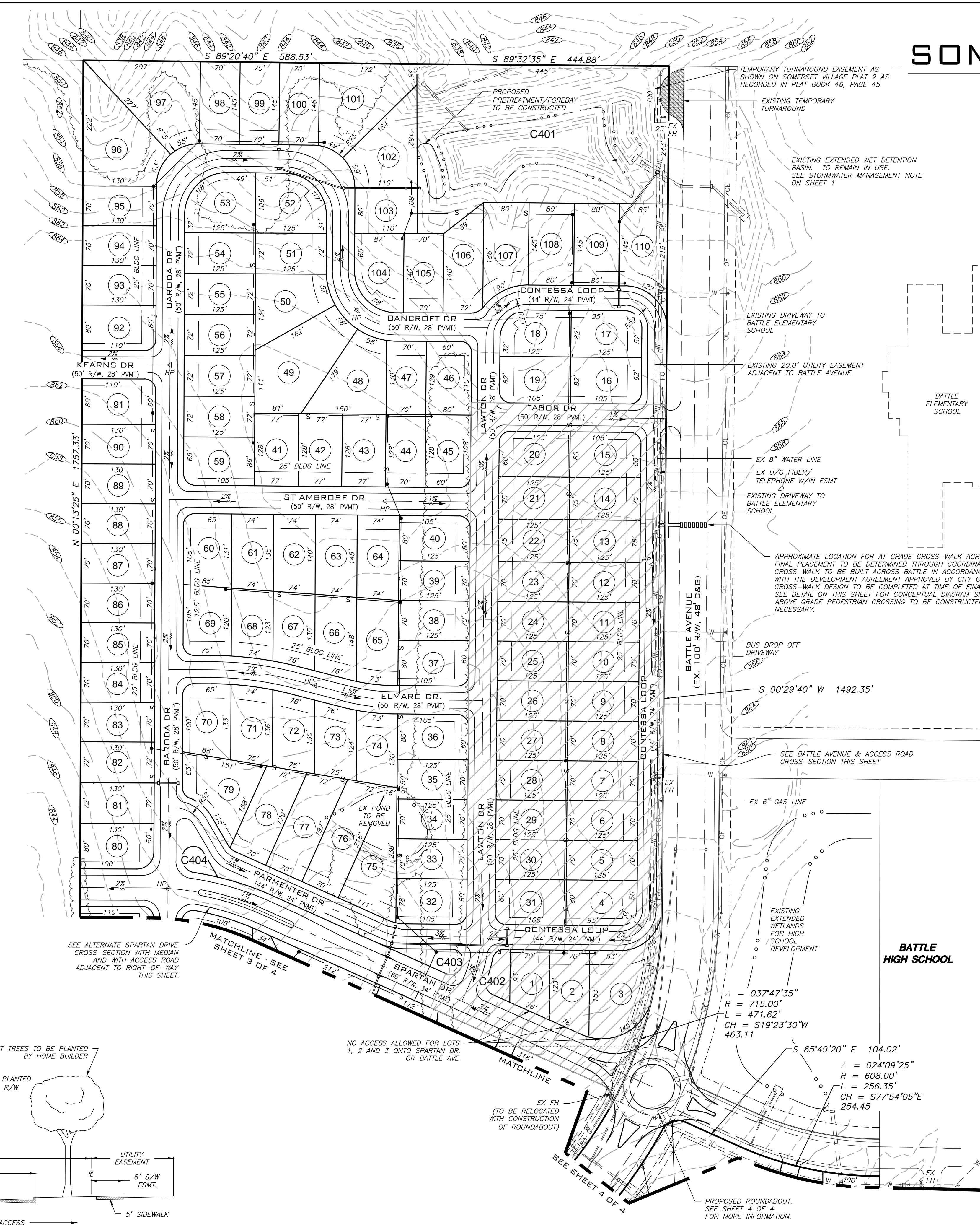

SURVEY AND PLAT BY
 A CIVIL GROUP
 CORPORATE NO. 2001006116
 THIS DOCUMENT HAS BEEN
 ELECTRONICALLY
 SIGNED, SEALED AND DATED
 GODY ALAN DARR
 PE-2012018055
 DECEMBER 21, 2015
 SCALE: 1" = 100'
 0 50 100 200
 SHEET 2 OF 4

A CIVIL GROUP
 CIVIL ENGINEERING - PLANNING - SURVEYING
 3401 BROADWAY BUSINESS PARK COURT
 SUITE 105
 COLUMBIA, MD 65203
 PH: (573) 817-5750, FAX: (573) 817-1677
 MISSOURI CERTIFICATE OF AUTHORITY: 2001006115

PRELIMINARY PLAT
**SOMERSET VILLAGE,
 PLAT NO. 2**

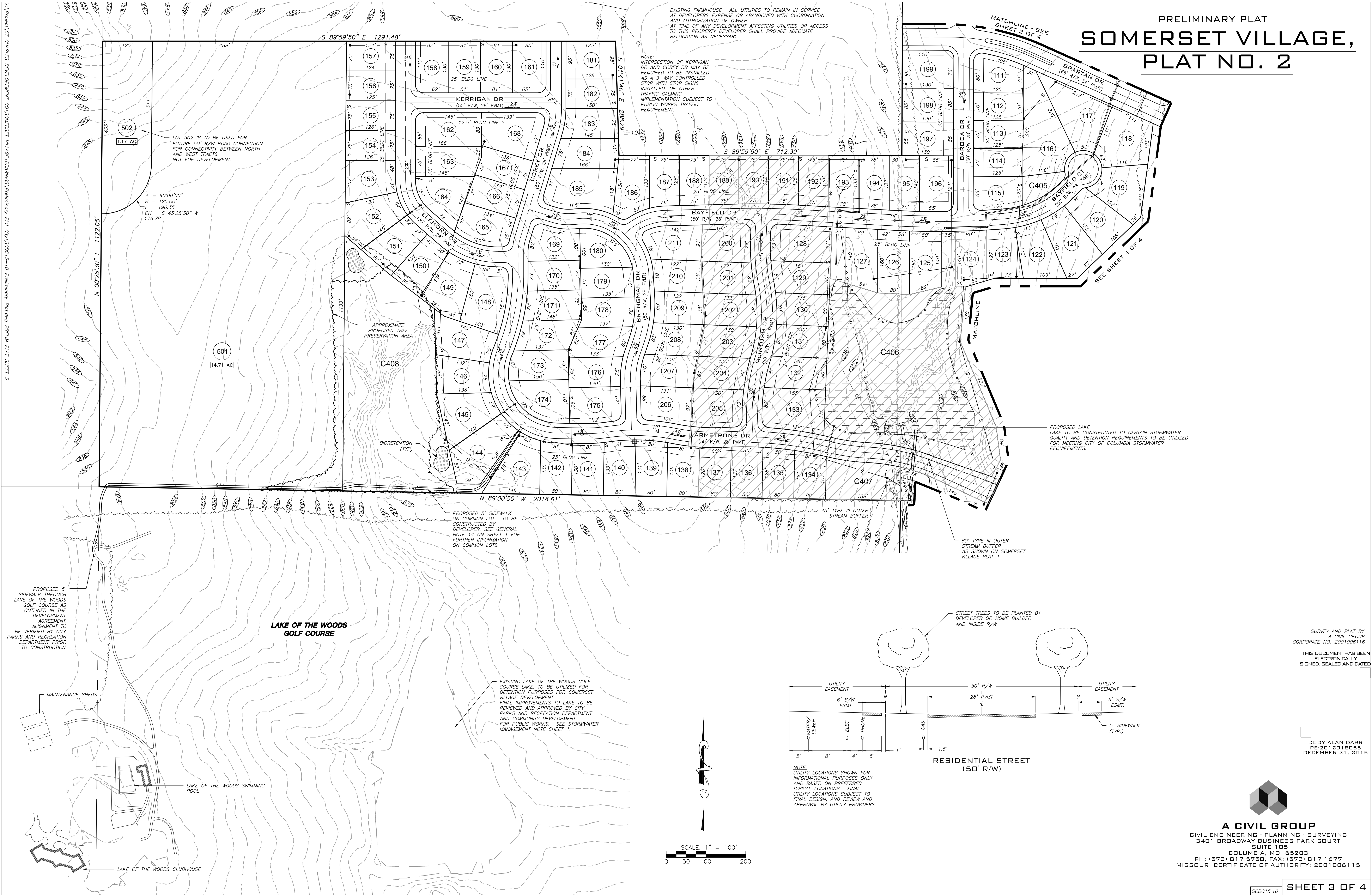

EXISTING FARMHOUSE. ALL UTILITIES TO REMAIN IN SERVICE AT DEVELOPER'S EXPENSE OR ABANDONED WITH COORDINATION AND AUTHORIZATION OF OWNER. AT TIME OF ANY DEVELOPMENT AFFECTING UTILITIES OR ACCESS TO THIS PROPERTY DEVELOPER SHALL PROVIDE ADEQUATE RELOCATION AS NECESSARY.

NOTE: INTERSECTION OF KERRIGAN DR AND COREY DR MAY BE REQUIRED TO BE INSTALLED AS A 3-WAY CONTROLLED STOP WITH STOP SIGNS INSTALLED, OR OTHER TRAFFIC CALMING IMPLEMENTATION SUBJECT TO PUBLIC WORKS TRAFFIC REQUIREMENT.

LOT 502 IS TO BE USED FOR FUTURE 50' R/W ROAD CONNECTION FOR CONNECTIVITY BETWEEN NORTH AND WEST TRACTS. NOT FOR DEVELOPMENT.

$\theta = 90^{\circ}00'00''$
 $R = 125.00'$
 $L = 196.35'$
 $CH = S 45^{\circ}28'30'' W 176.78'$

PROPOSED LAKE LAKE TO BE CONSTRUCTED TO CERTAIN STORMWATER QUALITY AND DETENTION REQUIREMENTS TO BE UTILIZED FOR MEETING CITY OF COLUMBIA STORMWATER REQUIREMENTS.

PROPOSED 5' SIDEWALK ON COMMON LOT. TO BE CONSTRUCTED BY DEVELOPER. SEE GENERAL NOTE 14 ON SHEET 1 FOR FURTHER INFORMATION ON COMMON LOTS.

60' TYPE III OUTER STREAM BUFFER AS SHOWN ON SOMERSET VILLAGE PLAT 1

PROPOSED 5' SIDEWALK THROUGH LAKE OF THE WOODS GOLF COURSE AS OUTLINED IN THE DEVELOPMENT AGREEMENT. ALIGNMENT TO BE VERIFIED BY CITY PARKS AND RECREATION DEPARTMENT PRIOR TO CONSTRUCTION.

LAKE OF THE WOODS GOLF COURSE

EXISTING LAKE OF THE WOODS GOLF COURSE LAKE. TO BE UTILIZED FOR DETENTION PURPOSES FOR SOMERSET VILLAGE DEVELOPMENT. FINAL IMPROVEMENTS TO LAKE TO BE REVIEWED AND APPROVED BY CITY PARKS AND RECREATION DEPARTMENT AND COMMUNITY DEVELOPMENT FOR PUBLIC WORKS. SEE STORMWATER MANAGEMENT NOTE SHEET 1.

STREET TREES TO BE PLANTED BY DEVELOPER OR HOME BUILDER AND INSIDE R/W

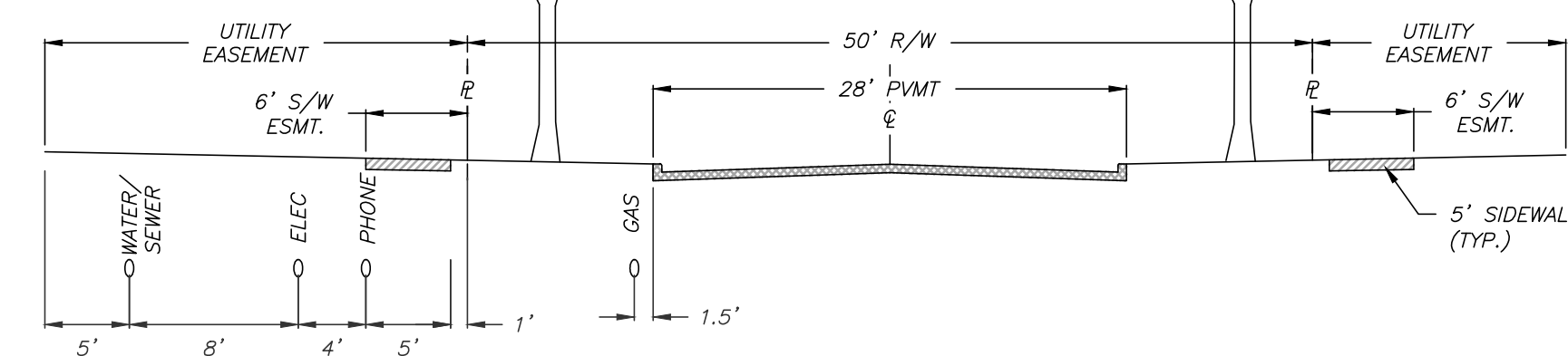

NOTE: UTILITY LOCATIONS SHOWN FOR INFORMATIONAL PURPOSES ONLY AND BASED ON PREFERRED TYPICAL LOCATIONS. FINAL UTILITY LOCATIONS SUBJECT TO FINAL DESIGN, AND REVIEW AND APPROVAL BY UTILITY PROVIDERS

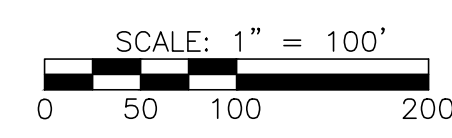

SURVEY AND PLAT BY
 A CIVIL GROUP
 CORPORATE NO. 2001006116
 THIS DOCUMENT HAS BEEN
 ELECTRONICALLY
 SIGNED, SEALED AND DATED

CODY ALAN DARR
 PE-2012018055
 DECEMBER 21, 2015



A CIVIL GROUP
 CIVIL ENGINEERING - PLANNING - SURVEYING
 3401 BROADWAY BUSINESS PARK COURT
 SUITE 105
 COLUMBIA, MD 65203
 PH: (573) 817-5750, FAX: (573) 817-1677
 MISSOURI CERTIFICATE OF AUTHORITY: 2001006115

PRELIMINARY PLAT
**SOMERSET VILLAGE,
 PLAT NO. 2**

K:\Project\ST CHARLES DEVELOPMENT CO\SOMERSET VILLAGE\DRAWINGS\Preliminary Plat City\SCDC15-10 Preliminary Plat.dwg PRELIM PLAT SHEET 4

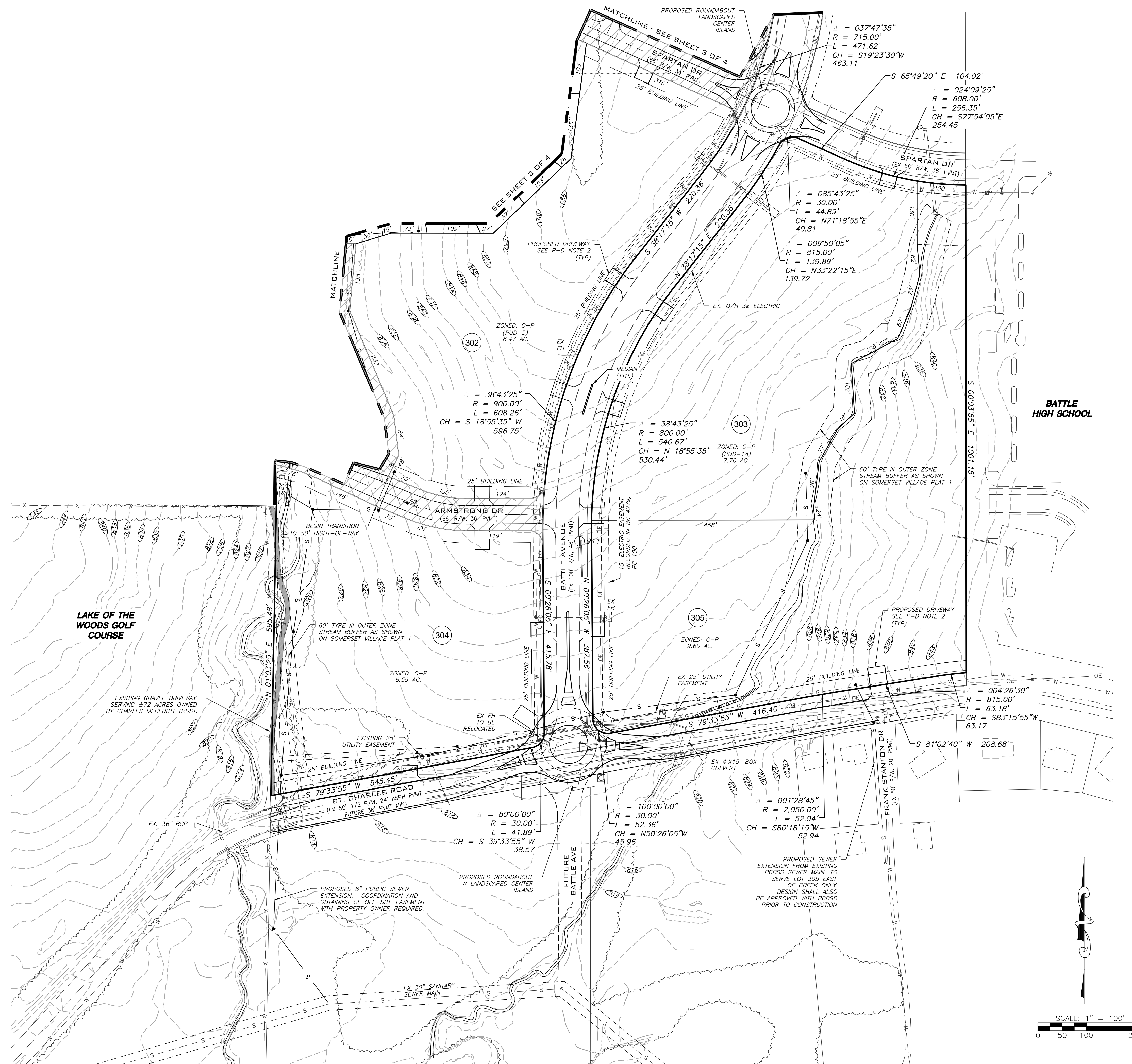

- PLANNED DISTRICT NOTES:**
- TRACTS 302, 303, 304, AND 305 ARE SUBJECT TO ALL CONDITIONS WITHIN THE DEVELOPMENT AGREEMENT APPROVED BY THE CITY OF COLUMBIA COUNCIL ORDINANCE NO. _____ AND THE STATEMENT OF INTENTS APPROVED WITH THE ANNEXATION AND REZONING IN ASSOCIATION WITH THAT ORDINANCE.
 - DRIVEWAYS HAVE BEEN SHOWN PER THE DEVELOPMENT AGREEMENT AND STATEMENT OF INTENTS FOR REFERENCE ONLY. FURTHER REFINED DESIGN ACCESS SPECIFICATIONS TO BE REVIEWED AND APPROVED WITH SITE SPECIFIC DEVELOPMENT PLANS.
 - ST. CHARLES ROAD AND BATTLE AVENUE ROUNDABOUT SHALL BEGIN TO BE CONSTRUCTED AND THE SIGNALIZED INTERSECTION ELIMINATED UPON APPROVAL OF A DEVELOPMENT PLAN FOR ANY OF TRACTS 303, 304, 305 (CORRESPONDING TRACTS 3, 4, AND 5 OF THE DEVELOPMENT AGREEMENT).
 - ST. CHARLES ROAD AND BATTLE AVENUE ROUNDABOUT SHALL BE EXPANDABLE FOR FUTURE TWO LANES IN THE NORTH-SOUTH DIRECTION.
 - SPARTAN DRIVE AND BATTLE AVENUE ROUNDABOUT SHALL BEGIN TO BE CONSTRUCTED UPON THE FIRST TO OCCUR OF EITHER:
 - APPROVAL OF FINAL PLATS FOR NO FEWER THAN 100 SINGLE FAMILY RESIDENTIAL LOTS; OR
 - APPROVAL OF A DEVELOPMENT PLAN FOR LOT 302 (CORRESPONDING TRACT 2 OF THE DEVELOPMENT AGREEMENT).
 - ALL DESIGN UTILITY/ACCESS/RIGHT-OF-WAY CONSIDERATION FOR THE CONSTRUCTION OF THE ROUNDABOUTS TO BE COORDINATED WITH THE APPLICABLE AGENCIES AND REGULATORY ENTITIES AT THE TIME OF DESIGN. ADDITIONAL RIGHT-OF-WAY SHALL BE DEDICATED FOR ROUNDABOUT CONSTRUCTION AS NECESSARY.
 - DEVELOPMENT AGREEMENT IS CONTINGENT UPON THE CITY'S ACCEPTANCE OF ST. CHARLES ROAD ADJACENT TO SUBJECT PROPERTY. HOWEVER, UNTIL SUCH TIME THAT CITY OF COLUMBIA IS PERMITTING AUTHORITY FOR ACCESS OFF OF ST. CHARLES ROAD ALL ACCESS AND IMPROVEMENTS ONTO ST. CHARLES ROAD SHALL BE SUBJECT TO REVIEW AND APPROVAL BY BOONE COUNTY.
 - A NORTH-SOUTH (GENERALLY PARALLEL TO BATTLE AVENUE) ACCESS THROUGH LOTS 302 AND 304 (TRACTS 2 AND 4 IN THE DEVELOPMENT AGREEMENT) FOR EMERGENCY PURPOSES SHALL BE PROVIDED. ACCESS SHALL BE FROM ST CHARLES ROAD TO ARMSTRONG DRIVE ON LOT 304. ACCESS SHALL BE FROM ARMSTRONG ROAD TO SPARTAN DRIVE ON LOT 302. DESIGN TO BE REVIEWED AND APPROVED AT TIME OF SITE SPECIFIC DEVELOPMENT PLAN OF LOTS 302 AND 304.
 - AN 8' PEDESTAL SHALL BE CONSTRUCTED ALONG THE NORTH SIDE OF ST. CHARLES ROAD WITH A TEMPORARY PAVED CONNECTION TO ST CHARLES ROAD AT THE WEST TERMINUS TO ALLOW FOR INTERIM USE.

**BATTLE
 HIGH SCHOOL**

**LAKE OF THE
 WOODS GOLF
 COURSE**

SURVEY AND PLAT BY
 A CIVIL GROUP
 CORPORATE NO. 2001006116
 THIS DOCUMENT HAS BEEN
 ELECTRONICALLY
 SIGNED, SEALED AND DATED

CODY ALAN DARR
 PE-2012018055
 DECEMBER 21, 2015

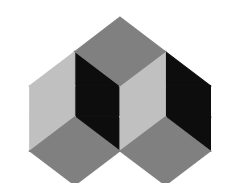

A CIVIL GROUP
 CIVIL ENGINEERING - PLANNING - SURVEYING
 3401 BROADWAY BUSINESS PARK COURT
 SUITE 105
 COLUMBIA, MD 65203
 PH: (573) 817-5750, FAX: (573) 817-1677
 MISSOURI CERTIFICATE OF AUTHORITY: 2001006115

