

- Notes:
- 1 Place inlet protection on downstream inlets.
 - 2 Contractor to verify underground utilities depth and locations.
 - 3 Construction staking will be complete by the city.
 - 4 Contractor shall coordinate with businesses and keep access open to businesses. Temporary access measures will be considered incidental to work.
 - 5 Existing brick that is removed shall be cleaned, pallet and salvaged to the city.
 - 6 Contractor to pay for the parking spaces as needed for construction.

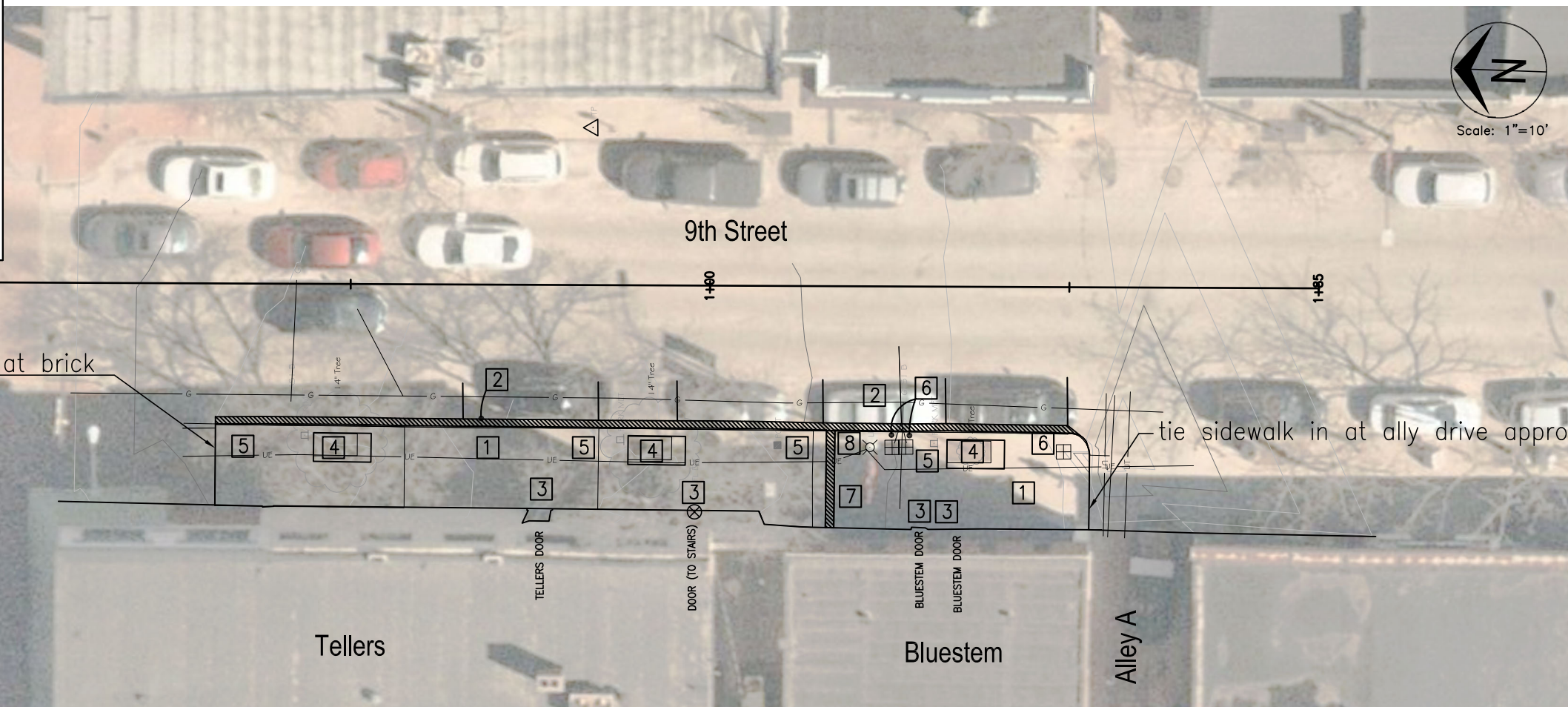

No.	Date	By	Revision

NINTH STREET SIDEWALK
 Plan and Details

- 1 Saw cut and remove existing sidewalk. Construct 4" Concrete Sidewalk with integral curb. (Downtown sidewalk, Detail 1000.02)
- 2 Saw cut remove pavement as needed for Sidewalk construction (assume 1' width). (Patch pavement, Detail 1000.04)
- 3 Construct concrete landing at door.
- 4 Install planter frame for 4'x8' tree planter. (Detail 1000.09, Aaron Steel has specifications) Parks + Recreation will remove the trees.
- 5 Remove and replace bike rack, meters.
- 6 Adjust values/meters.
- 7 Install trench grate with Type P lid. (Detail 1000.16)
- 8 Light pole to remain in place.

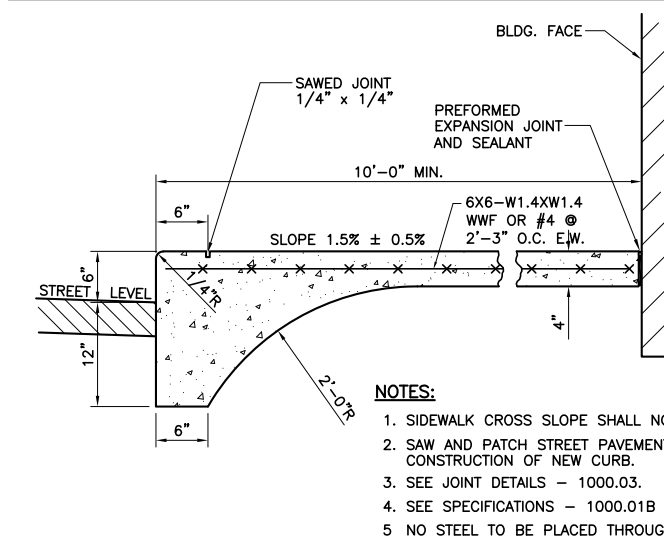

DOWNTOWN SIDEWALK DETAIL

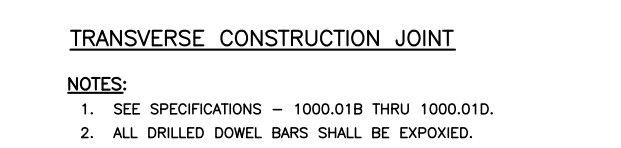
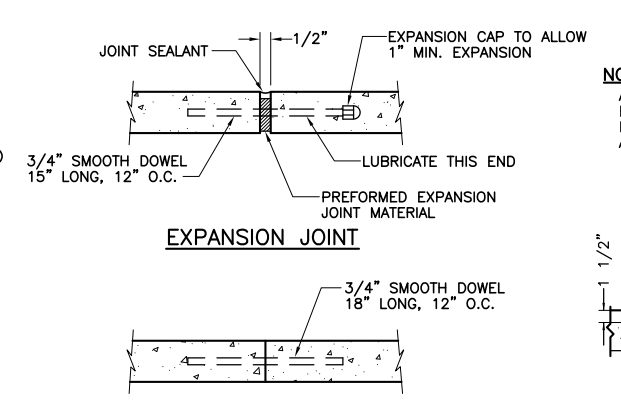
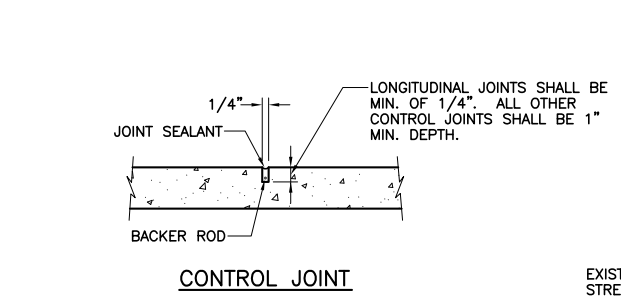
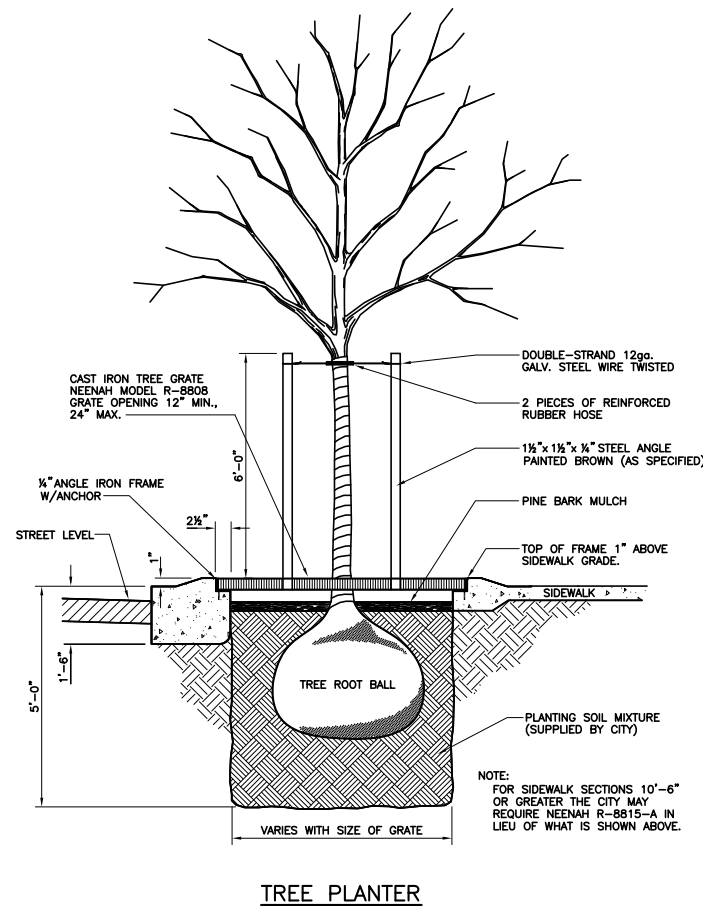

- NOTES:**
1. SEE SPECIFICATIONS - 1000.01B THRU 1000.01D.
 2. ALL DRILLED DOWEL BARS SHALL BE EXPOXIED.

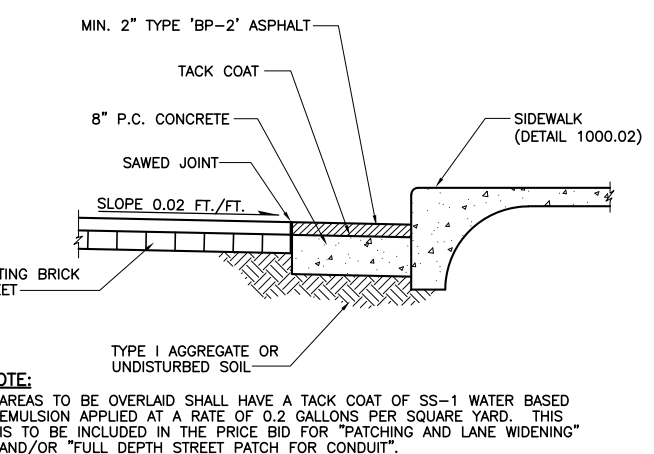

- NOTE:**
- AREAS TO BE OVERLAID SHALL HAVE A TACK COAT OF SS-1 WATER BASED EMULSION APPLIED AT A RATE OF 0.2 GALLONS PER SQUARE YARD. THIS IS TO BE INCLUDED IN THE PRICE BID FOR "PATCHING AND LANE WIDENING" AND/OR "FULL DEPTH STREET PATCH FOR CONDUIT".

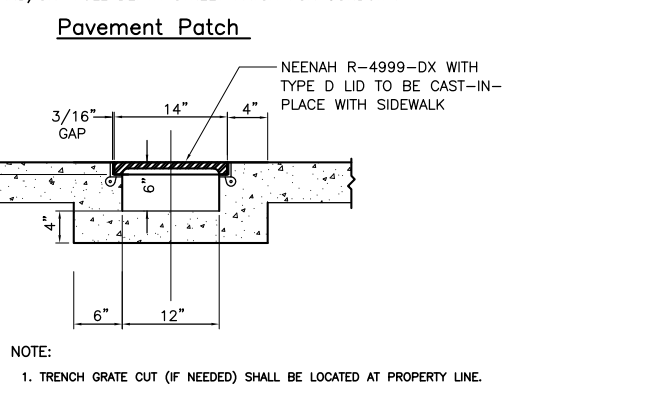

Mission
Provide safe, sustainable infrastructure that promotes positive communities.

701 East Broadway
P.O. Box 6015
Columbia, MO 65205
(573) 875-2489



Shane Steven Creech
Registered Professional Engineer
PE-2007011061

File No.	00000
Scale:	1:10
Date:	2/28/2023
Des.	A.A.A.
Dwn.	A.A.E.
Chk.	A.A.A.

c:\cadpro\sidewalk\Broadway (ninth to 10th)\design\Ninth Street Sidewalk_base.dwg

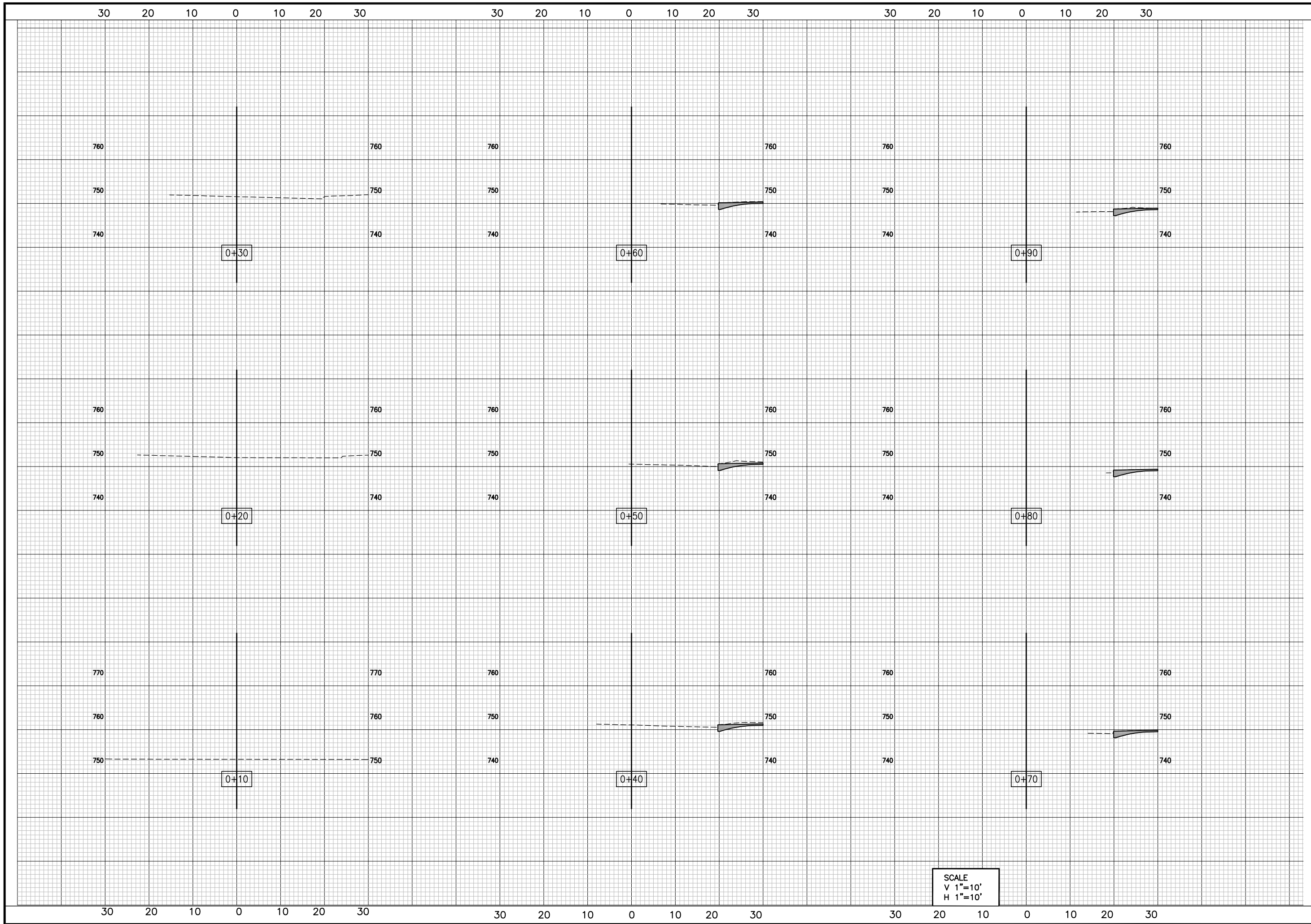

No.	Date	By	Revision

NINTH STREET SIDEWALK

Cross Sections Sta. 0+10 to Sta. 0+90

Mission
Provide safe, sustainable
infrastructure that promotes
positive communities.

701 East Broadway
P.O. Box 80115
Columbia, MO 65205
(573) 875-2488

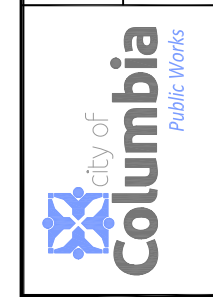

Shane Steven Creech
Registered Professional
Engineer
PE-2007011061

File No.	00000
Scale:	1:10
Date:	2/28/2023
Des.	A.A.A
Dwn.	A.A.E
Chk.	A.A.A

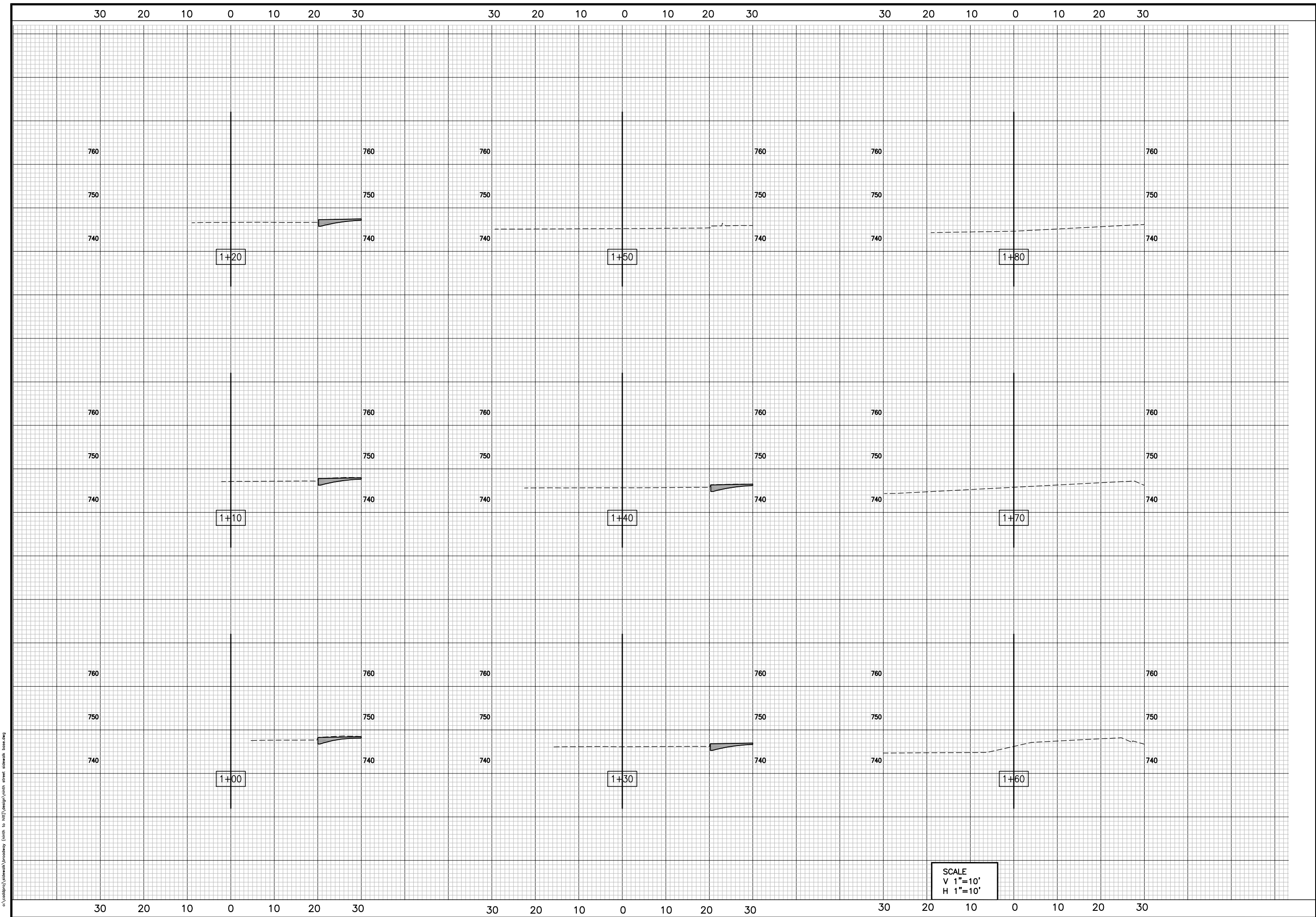

c:\addproj\sidewalk\roadway (rnh to hnt)\design\with street sidewalk base.dwg

No.	Date	By	Revision

NINTH STREET SIDEWALK

Cross Sections Sta. 1+00 to Sta. 1+80

Mission
Provide safe, sustainable infrastructure that promotes positive communities.

701 East Broadway
P.O. Box 6015
Columbia, MO 65205
(573) 875-2489

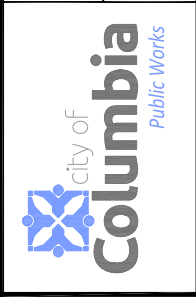

Shane Steven Creech
Registered Professional Engineer
PE-2007011061

File No.	00000
Scale:	1:10
Date:	2/28/2023
Des.	A.A.A
Dwn.	A.A.E
Chk.	A.A.A



TRAFFIC CONTROL PLAN
SCALE: 1"=20'

CITY WILL BE RESPONSIBLE FOR COSTS ASSOCIATED WITH CLOSURE OF THE PARKING SPACES TO COMPLETE THE WORK.

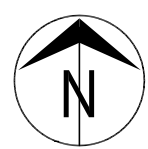

WS^2
 $L=60$
S=SPEED LIMIT
W=WIDTH OF TAPER

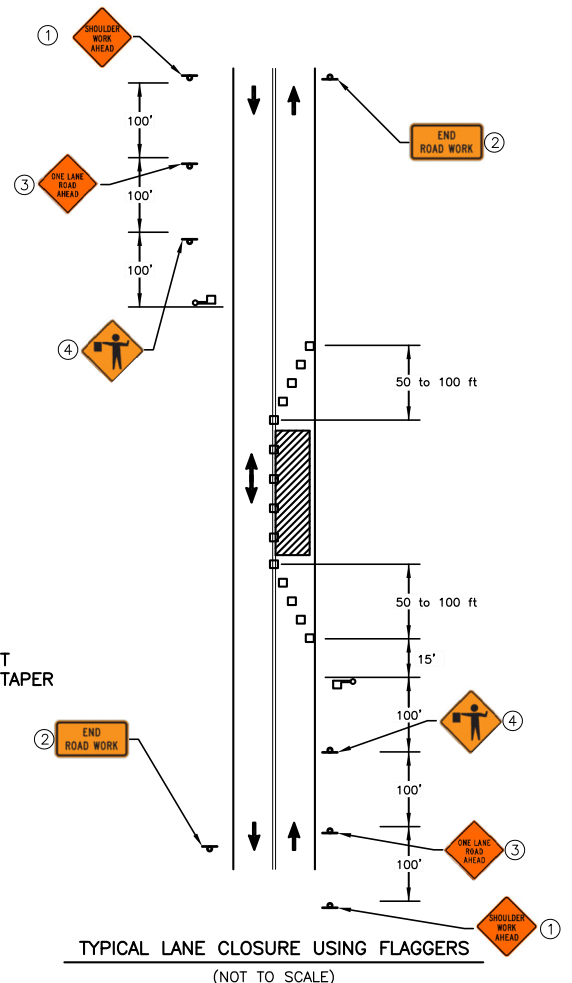

TYPICAL LANE CLOSURE USING FLAGGERS
(NOT TO SCALE)

MUTCD CODE	DESCRIPTION	SIZE	QUANTITY
① W21-5	"ROAD WORK AHEAD"	36"x36"	6
② G20-2	"END ROAD WORK"	36"x18"	3
③ W20-4	"ONE LANE ROAD AHEAD"	36"x36"	2
④ W20-7	FLAGGER SIGN	36"x36"	2

LEGEND

①	SIGN
②	CHANNELIZER
③	FLAGGER
④	WORK ZONE



TRAFFIC CONTROL GENERAL NOTES:

- IT IS THE RESPONSIBILITY OF THE CONTRACTOR TO INSURE THAT ALL BARRICADES, SIGNS, OTHER TRAFFIC CONTROL DEVICES AND PLACEMENT THEREOF SHALL CONFORM TO THE CURRENT EDITION OF THE MANUAL ON UNIFORM TRAFFIC CONTROL DEVICES (MUTCD).
- THE CONTRACTOR SHALL NOTIFY THE CITY JOINT COMMUNICATIONS OFFICE OF ALL ROAD CLOSURES OR LANE REDUCTIONS IN ADVANCE. JOINT COMMUNICATIONS PHONE NUMBER IS (573) 874-7400.
- TRAFFIC CONTROL DEVICES SHALL BE IN PLACE PRIOR TO BEGINNING CONSTRUCTION. ACTUAL QUANTITIES WILL DEPEND ON THE CONTRACTOR'S CONSTRUCTION SEQUENCE AND PROGRESS. NO MEASUREMENT WILL BE MADE OF ACTUAL QUANTITIES. QUANTITIES SHOWN ARE APPROXIMATE.
- CONTRACTOR SHALL MAINTAIN ACCESS TO ALL PROPERTIES IN THE CONSTRUCTION ZONE TO THE MAXIMUM EXTENT PRACTICABLE.
- NO OPEN TRENCHES WILL BE ALLOWED OVERNIGHT OUTSIDE OF THE "ROAD CLOSED" AREA. ASPHALTIC "COLD MIX" SHALL BE USED AS A TEMPORARY PATCH OVERNIGHT. TEMPORARY PATCHING SHALL BE CONSIDERED INCIDENTAL TO THE WORK.
- ALL OPEN TRENCHES ARE TO BE BARRICADED WITH CONSTRUCTION FENCING.
- THE DISTANCE BETWEEN TEMPORARY TRAFFIC CONTROL SIGNS MAY BE ADJUSTED ACCORDING TO FIELD CONDITIONS.

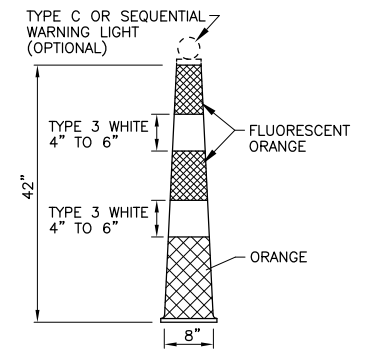

REFLECTIVE SHEETING APPLIED TO CHANNELIZERS SHALL BE REBOUNDABLE MEETING ASTM D 4956.

TRIM LINE CHANNELIZER
N.T.S.

No.	Date	By	Revision

NINTH STREET SIDEWALK
Traffic Control Sheet 1

Mission
Provide safe, sustainable infrastructure that promotes positive communities.
701 East Broadway
P.O. Box 6015
Columbia, MO 65205
(573) 875-2489

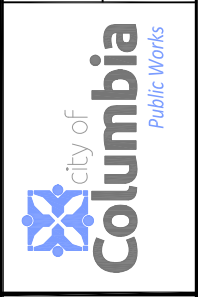

Shane Steven Crech
Registered Professional Engineer
PE-2007011061

File No.	00000
Scale:	None
Date:	2/28/2023
Des.	A.A.A
Dwn.	A.A.E
Chk.	A.A.A

c:\addone\sidewalk\roadway (ninth to ninth)\design\ ninth street sidewalk base.dwg