

MALICOAT-WINSLOW ENGINEERS, P.C.
MECHANICAL AND ELECTRICAL ENGINEERS

5649 NORTH CLEARVIEW ROAD
COLUMBIA, MISSOURI 65202-9687

FREDDIE L. MALICOAT, P.E.
email: fredm@mwengrs.com

Phone: 573-875-1300
Fax: 573-875-1305

August 4, 2020

City of Columbia
701 E Broadway
Columbia, MO 65205

Re: City of Columbia Data Room HVAC

City Council Members:

The units were purchased to eliminate the need to operate a 270 Ton chiller (for the entire building) during the winter months for a 24 Ton load in the computer room.

The cost estimate for this project is approximately \$72,500 - \$79,750.

If you have any questions or comments, please call me at (573) 489-5122.

Sincerely,



Fred Malicoat
FM:ekp

The Engineer of Record for Section 02 4119 and Divisions 23 and 26 of the Specifications for the City of Columbia Data Room HVAC in Columbia, MO is:



7-29-20

DIVISION 02
SECTION 02 4119
DEMOLITION

PART I - GENERAL

1.01 SECTION INCLUDES

- A. Removal of existing data room HVAC units including electrical, refrigerant, and refrigerant piping that is accessible.
- B. Disposal of materials.

1.02 REGULATORY REQUIREMENTS

- A. Conform to applicable code for demolition work.
- B. Obtain required permits from authorities.
- C. Do not close or obstruct egress from any building exit or site exit.
- D. Do not disable or disrupt building fire or life safety systems without 3 days' prior written notice to Owner.
- E. Conform to applicable regulatory procedures when hazardous or contaminated materials are discovered.

1.03 PROJECT CONDITIONS

- A. Conduct demolition to minimize interference with adjacent and occupied building areas.
- B. Cease operations immediately if structure appears to be in danger and notify Engineer. Do not resume operations until directed.

PART II - PRODUCTS - NOT USED

PART III - EXECUTION

3.01 PREPARATION

- A. Provide, erect, and maintain temporary barriers at locations indicated by Owner.
- B. Erect and maintain weatherproof closures for roof openings.

- C. Protect existing materials that are not to be demolished.
- D. Notify affected areas before starting work and comply with their requirements.
- E. Mark location and termination of utilities.
- F. Provide appropriate temporary signage including signage for exit or building egress.

3.02 DEMOLITION

- A. Disconnect, remove, and identify designated utilities within demolition areas.
- B. Demolish in an orderly and careful manner. Protect existing supporting structural members.
- C. Remove demolished materials from site except where specifically noted otherwise. Do not burn or bury materials on site.
- D. Remove materials as demolition progresses. Upon completion of demolition, leave areas in clean condition.
- E. Remove temporary facilities.

END OF SECTION

DIVISION 23
SECTION 230000
HEATING, VENTILATING, AND AIR CONDITIONING

PART I - GENERAL

1.01 Related Documents

- A. Provision of General Requirements, Division 1, are a part of this section.

1.02 Description of Work

- A. The extent of work is shown on drawings, and includes but is not necessarily limited to the following:
 - 1. Condensate Piping and Insulation
 - 2. Controls
 - 3. Exhaust Fans
 - 4. Refrigerant Piping
- B. Prior to bidding, all Contractors shall visit the site and become familiar with all existing conditions, which will affect construction procedures and scope of work required as part of this Section.

1.03 Related Work

- A. Power and control wiring
- B. Painting
- C. Cutting and patching

1.04 CODES AND STANDARDS

- A. American Society of Mechanical Engineers
- B. American Society for Testing and Materials
- C. American Society of Heating, Refrigerating and Air Conditioning Engineers.
- D. International Building Code
- E. Underwriter's Laboratories
- F. NFPA

G. International Approval Service

PART II - PRODUCTS

2.01 Exhaust Fans

- A. Shall be as scheduled or equal.

2.02 Controls

- A. Furnish & install thermostats, transformers, relays etc. as required to provide control sequence as specified. See Division 16 for temperature control conduit & conductors by this Division.

2.03 Computer Room Air Conditioners

- A. Shall be furnished by owner and installed by contractor.

2.04 Refrigerant Piping

- A. Refrigerant piping shall be type ACR cleaned and capped hard drawn copper refrigerant pipe with wrought copper fittings and silver soldered joints.
- B. System shall be insulated, evacuated, and charged per manufacturers written installation instructions.
- C. Support piping to prevent sagging.
- D. Paint exposed refrigerant pipe insulation or cover with UV jacket.

PART III - EXECUTION

3.01 Manufacturer's Written Installation Instructions

- A. All materials shall be installed as recommended by manufacturer. Nothing in these specifications shall be construed to vary from manufacturer's written installed instructions without written approval from manufacturer.
- B. It shall be the responsibility of this Contractor to coordinate with the other trades for clearance, elevations, etc., before the installation of any material. Where conflicts exist the Engineer shall be notified before installing material. Changes required in work specified in this Section caused by neglect to do so shall be made at no cost to the Owner.

- C. Arrange with Contractors of other trades for installation of built-in items, blocking, and additional necessary supports.

3.02 Computer Room Air Conditioning

- A. Install complete and operable air conditioning system.

3.03 Noise and Vibration

- A. It is the specific intent of these specifications and design conditions that the system including equipment, piping and other parts, shall be noiseless and free of vibration as a result of the new installation in the building. It shall be the responsibility of this Contractor to correct these conditions at no cost to the Owner.

3.04 Testing, Adjusting and Air Balancing

- A. All systems and equipment shall be put into operation and shall continue to operate for at least three, eight-hour periods until all adjusting, balancing, testing, demonstrations, instruction and cleaning of system have been completed.

3.05 Operating Instructions and Maintenance Data.

- A. Upon completion and acceptance of the work by the Owner, the Contractor shall provide an experienced Engineer to instruct the Owner's operators in operation of entire installation. Instruction period shall be for a period of one (1) four-hour working period. Contractor shall provide four (4) sets of 8 1/2" x 11" typed operating and maintenance instructions. Sample maintenance instructions will be provided by Engineer upon request. Contractor shall also include wiring diagrams of all controls in each set of maintenance instructions.

3.06 Clean-up

- A. Upon completion of work under this Section, all unnecessary equipment, materials, rubbish, etc., shall be removed from project site and surrounding area leaving site in a safe and cleared condition.

3.07 Piping Installation

- A. All piping shall be run parallel and/or perpendicular to building lines and shall be neatly grouped.
- B. See drawings for general routing of pipes and see details of drawings for specific pipe routing.

- C. All piping shall be supported in a manner to prevent the weight of any piping, valves, fittings, etc. from being born be equipment connections.
- D. Insulate A/C condensate line (inside building), with 3/8" Armaflex.

3.08 Hanger Installation

- A. Install hangers on maximum 8 ft centers for 1/2" thru 2" steel pipe and maximum 10 ft centers for 2 1/2" steel pipe and larger. Install hangers at maximum 4'-0" O.C. for plastic pipe. Provide rigid insulation of wood blocks and size hangers for O.D. of insulation. Sheet metal saddles on all insulated piping.

3.09 Temperature Controls

- A. Furnish and install electronic cooling thermostat for each unit.

3.10 Cutting, Patching and Piercing

- A. Obtain written permission of the Engineer before cutting or piercing structural members. If, in the process of the mechanical work, piping or equipment need to be installed in an area after it has been completed, the area shall be left in the same condition it was originally. Patching and/or refinishing will be determined by the Engineer.

3.11 Access

- A. Equipment, valves and devices shall be mounted in a manner which provides adequate maintenance, inspection access and work space. Where access is required for adjustment, cleanout, inspection of maintenance and such access is not otherwise available, access panels shall be furnished and installed. Panels shall be selected by the Engineer.

3.12 Building Openings for Admission or Installation of Equipment

- A. The Contractor shall ascertain from his examination of the site whether any special temporary or permanent openings in the building for the admission or installation of apparatus furnished under this Contract will be necessary and he shall pay all cost of making such openings.

3.13 Cutting, Sleeves, Inserts, Anchor Bolts and Escutcheons

- A. In placing sleeves, inserts, anchor bolts and any other material, the Contractor shall cooperate with all other trades and shall consult with the Engineer in regard to their exact location whenever there is any interference with structural members.

- B. The Contractor will be held responsible for locating and maintaining in proper position, sleeves, inserts and anchor bolts supplied and/or set in place by him. In the event that failure to do so requires cutting and patching of finished work, it shall be done at the Contractor's expense.
- C. All pipe passing through floors, walls or partitions shall be provided with sleeves having an internal diameter 1" larger (unless specifically indicated otherwise) than the outside diameter of the pipe. All holes cut in floor panels shall be core drilled.
- D. Sleeves through outside walls shall be Schedule 40 black steel pipe. Sleeves shall extend 1/2' beyond each side of the wall. The space between the sleeve and the pipe shall be packed and made water tight with a waterproof compound.
- E. Sleeves through masonry floors, interior masonry walls, or fire walls shall be Schedule 40 steel pipe set flush with finished wall or ceiling surfaces, but extending 2" above finished floors.
- F. Sleeves through interior partitions shall be 22 gauge galvanized sheet steel set flush with finished surface of partitions.
- G. Inserts shall be individual or strip type of pressed steel construction with accommodation for removable nuts and threaded rods up to 3/4" in diameter, permitting lateral adjustment. Individual inserts shall have an opening at the top to allow reinforcing rods to be passed through the insert body and shall be similar to Fee and Mason Fig 188 or equal for equipment suspension and Fig. 9000 or equal for pipe suspension.
- H. Where sleeves or inserts are placed in interior walls or partitions, the openings shall be completely sealed with Fiberglass to prevent sound transmission. Where sleeves are placed in fire rated walls, they shall be packed with high temperature mineral wool and non-flammable sealant.
- I. Furnish and install escutcheons where uninsulated pipes pass through finished walls, floors or ceilings. Escutcheons shall be chrome plated brass, firmly secured to the pipes and of sufficient out side diameter to amply cover the sleeved openings for the pipes. Escutcheon plates shall be as manufactured by Crane Company or equal.

END OF SECTION

DIVISION 26
SECTION 260000
ELECTRICAL

PART I - GENERAL

1.01 Related Documents

- A. Provisions of General Requirements, Division 1, are a part of this section.

1.02 This work shall include, but not necessarily be limited to furnishing and installing:

- A. Wiring
- B. Conductors and Conduit
- C. Fused Disconnects.
- D. Wiring Devices.
- E. Wiring for Equipment Furnish by Others.
- F. Grounding
- G. Drawings of Record
- H. Prior to bidding, all Contractors shall visit the site and become familiar with all existing conditions, which will affect construction procedures and scope of work required as part of this Section.

1.03 Codes and Standards

- A. National Fire Protection Association - National Fire Code.
- B. National Electrical Code
- C. Building Officials and Code Administrators International, Inc.
- D. Underwriter's Laboratories
- E. National Electric Safety Code

- 1.04 Shop Drawings shall be submitted to the Engineer for approval. The Contractor shall be responsible for quantities and dimensions. The Contractor shall check all shop drawings prior to submission to the Engineer.
- 1.05 The Contractor shall follow the drawings in the layout of his work and shall consult general construction drawings, mechanical drawings and all other drawings for this project to determine all conditions affecting the electrical work. The drawings are not to be scaled and the Contractor shall verify spaces in which the electrical work is to be installed.
- 1.06 The Contractor shall take measurements and make layouts as required for the proper installation of the work and coordination with all other work on the project.
- 1.07 Related Work
- A. Mechanical Equipment

PART II - PRODUCTS

2.01 Wire and Cable

- A. Low voltage wire and cable
1. All wire and cable installed under this contract shall be Southwire, Anaconda, Triangle or approved equal, complete with non-fading type color coding system as set forth by National Electric Code. General interior wiring shall have 600 volt insulation, THHN. Wiring in wet and damp locations shall be THWN.
 2. Wire shall be soft annealed copper conforming to current requirements of National Electrical Code, and shall be Brown & Sharp (B&S), or American Wire Gauge (AWG) gauges unless specifically indicated on the Drawings. NO ALUMINUM WIRE SHALL BE USED. Wire smaller than #12 gauge shall not be used.

2.02 Connectors

- A. Shall be "Scotch Lok" for up to #8 wire and Weaver, or approved equal, split bolt or set screw type connectors for #6 wire and larger.

2.03 Conduit

- A. EMT electrical metallic tubing, Republic "Electriunite", National, Triangle.
- B. Rigid galvanized conduit, Republic "Galvanite", National, Triangle, with threaded fittings.

- C. Flexible metal conduit, "Greenfield".
- D. Carlon, or approved equal, Schedule 40 non-metallic conduit and fittings.
- E. Metal Clad (Type MC) cable and fittings manufactured by AFC, or approved equal.

2.04 Outlet, Junction and Pull Boxes

- A. Outlet boxes shall be galvanized or sherardized, one-piece pressed steel of sectional type or non metallic (Carlon), of size most suitable for the outlet used. Boxes shall be equipped with plaster rings, extension rings, bar hangers and fixture studs as may be required. Junction or pull boxes, either flush or surface mounted, as indicated or required, shall be of adequate sizes to accommodate the conductors installed therein. Junction and pull boxes shall comply with the National Electrical Code as to construction.

2.05 Fuses

- A. Fuses shall be Bussmann as follows or as noted on Drawings. Fuses 60 amps and above shall be NEMA class L Hi-cap "KRP-C" fuses with time delay. Fuses feeding circuit breaker panels shall be Limitron fuses, "KTN" for 250 volts. Fuses on power feeders shall be Fusetron Dual-Element fuses in the 0-60 amp sizes, "FRN" for 250 volts, and Low-Peak Dual Element fuses in the 70 to 600 amp sizes, "LPN" for 250 volts.
- B. Cabinets shall conform to NEMA standards, and be constructed of code gauge galvanized sheet steel with single door flush or surface trim as indicated on the Drawings.
- C. Cabinet trim shall have gray lacquer finish.

2.06 Fused Disconnects

- A. Shall be Square D, general duty, single throw, externally operated safety switches, fuses and of poles, volts and ampere ratings for the load shown in NEMA-1 or NEMA-3R enclosures, as required.

2.07 Substitutions

- A. All substitutions must be pre-approved by the Engineer prior to bidding. See Division 1 for substitution process.

PART III - EXECUTION

3.01 Manufacturer's Written Installation Instructions

- A. All materials shall be installed as recommended by manufacturer. Nothing in these specifications shall be construed to vary from manufacturer's written installed instructions without written approval from manufacturer.
- B. It shall be the responsibility of this Contractor to coordinate with the other trades for clearance, elevations, etc., before installation of any material. Where conflicts exist the Engineer shall be notified before installing material. Changes required in work specified in this section caused by neglect to do so shall be made at no cost to the Owner or Engineer.
- C. The Contractor shall verify the voltage phase full-load current and exact location of all electrical equipment before rough-in.
- D. Arrange with Contractors of other trades for installation of built-in items, blocking, and additional necessary supports.

3.02 Wire and Cable Installation

- A. Unless specifically indicated on Drawings, all wire and cable installed in ordinarily dry locations above base slab shall be Type THHN. Unless specifically indicated on Drawings, all wire installed below grade in slab or grade or in areas subjected to possible condensation, moisture, or weather shall be Type THWN.
- B. All wiring shall be in conduit, or shall be type MC cable. See "Conduit" below.
- C. All wiring shall be continuous between boxes with out any splices in conduit or frame spaces.

3.03 Conduit Installation

- A. Conduit for general use concealed inside building as shown on Drawings shall be EMT or type MC cable.
- B. All conduit for installation exposed or exterior to structure, or within concrete construction or as shown on Drawings, shall be rigid galvanized or Schedule 40 PVC as approved by Engineer.
- C. Conduit smaller than 1/2" shall not be used. Flexible conduit (Greenfield) may be used in short lengths (maximum 6') for fixture connections, motor connections and other special connections as approved by Engineer.

- D. Conduit shall be concealed in finished spaces, except where noted otherwise on Drawings. All exposed conduit shall be as approved by Engineer and shall be installed in a neat and workmanlike manner with conduit runs parallel to building lines.
- E. Conduit shall run continuous between outlets, boxes and cabinet, and each conduit run shall have not more than three 90 degree bends between termination points. Conduit shall bend without crimping or flattening to provide a smooth and even turn with bend radius as great as possible, never shorter than that used in corresponding trade elbow. Conduit bends in which interior enamel has flaked will not be permitted.
- F. Conduit shall be supported individually by use of bolted metal clamp type hangers at intervals not exceeding 8'-0' with each hanger rigidly attached to building construction. Vertical conduit supports, where required, shall be clamps attached to structure in an approved manner.
- G. Conduit ends shall be reamed and all burrs removed prior to installation, and all conduit shall be kept clean and dry during construction by use of caps and plug. Junction or pull boxes shall be installed as required to facilitate ease of wire pulling. Insulating bushings shall be provided on all conduits at points where entering metal enclosures to prevent abrasion and damage to insulation of wire and cable.
- H. Type MC cable installed in ceiling plenums shall be supported to prevent contact with T-bar ceilings.

3.04 Outlet, Junction and Pull Box Installation

- A. The size of each box shall be determined by the number of wires and conduits, or size of conduit entering the box, but shall be not less than 3 1/4" octagon or 4" square with ring.
- B. All single to four-gang outlet boxes required in unplastered masonry walls shall be 3 1/2" deep solid type with square corners. All plaster and masonry rings or boxes shall be flush or not more than 1/4" behind the finished surfaces.
- C. All boxes shall be securely anchored to masonry or frame construction.

3.05 Locations of Outlets and Equipment

- A. The Contractor shall coordinate his work with that of other trades in order to provide a proper installation of electrical equipment in keeping with the intent of the Drawings and Specifications. Minor changes relative to the location of

electrical equipment may be made by Owner's Representative to comply with structural and building requirements as determined in the course of construction.

3.06 Grounding

- A. The complete new electrical installation, including metallic boxes and equipment shall be permanently and effectually grounded in accordance with all code requirements, whether or not such connections are specifically shown and/or specified.
- B. Every branch and feeder conduit shall contain a green insulated code sized grounding conductor. Care shall be taken to keep the system neutral conductor separate from the equipment ground except at the point of system derivation.

3.07 Cutting and Patching

- A. Contractor shall perform all cutting and patching as required for all electrical work inside and outside of building.
- B. All conduit penetrations of rated walls will be sealed.

3.08 Wiring of Equipment Furnished by Others

- A. Electrical Contractor shall do all power wiring except factory prewired equipment.
- B. Furnish and install disconnects at all equipment not furnished with disconnect. Coordinate with HVAC Contractor to ensure all equipment has a properly sized electrical disconnect at the unit.
- C. Starters and thermal protective devices not a factory mounted integral part of equipment furnished by Section 15000, shall be furnished by the HVAC Contractor but installed and wired by the Electrical Contractor.

3.09 Drawings of Record

- A. A blueline or blackline copy of Drawing shall be kept at the job site at all times for the sole purpose of recording horizontal and vertical location of all below grade electrical wiring, referenced to permanent visible structures. At completion of job, neatly record all dimensions and submit for approval by Engineer.

3.10 Clean Up

- A. Upon completion of work under this Section, all unnecessary equipment, materials, rubbish, etc., shall be removed from project site and surrounding area leaving site in a safe and cleared condition.

3.11 Equipment Label Installation

- A. Front cover of each panel, fused disconnect, and other electrical equipment shall have a mechanically attached name plate indicating name/number of panel and second nameplate on subpanels indicating "Fed from (panel #)". Panel nameplates shall have 3/4" letters and secondary nameplates shall have 1/2" letters. Seton #818-2, or approved equal, 1/2" x 4".

3.12 Materials and Workmanship

- A. Only new, clean and perfect equipment, apparatus, materials and supplies of latest design and manufacture shall be incorporated in the work in order to assure an electrical system of high quality.
- B. All materials shall be new, shall bear the Underwriters Label of Approval and shall be installed according to manufacturer's specifications or as directed by the Engineer. The Contractor shall assume responsibility for proper installation of materials in the space available.

3.13 Erection of Apparatus

- A. All work shall be done under the supervision of the Contractor who shall provide foremen to lay out all work. All work shall be laid out with due regard for proper working clearances about electrical equipment and the space requirements of the other Contractors. The Contractor shall immediately report to the Engineer any conflict or difficulties in regard to the installation.
- B. Motor switches or controllers, switches, boxes, and other electrical apparatus shall be set, mounted, positioned, coupled, connected, assembled or otherwise erected or constructed as recommended by the manufacture or designer thereof, unless approved by the Engineer for erection in some other manner.
- C. Where crowded locations exist and where there is a possibility of conflict between the trades, the Contractor shall coordinate the exact locations of electrical work with the other trades. After consultation and agreement between the trades, the location shall be approved by the Engineer before installation of the work.
- D. Equipment of a type that requires replacement, servicing, adjusting, or maintenance shall be located to allow easy access and space for removal of internal assemblies if required.

3.14 Cutting, Patching and Piercing

- A. Obtain written permission of the Engineer before cutting or piercing structural members. If, in the process of the electrical work, circuits or equipment need to be installed in an area after it has been completed, the area shall be left in the same condition it was originally. Patching and/or refinishing will be determined by the Owners Representative. Sleeves through floors and walls to be black iron pipe flush with walls, ceilings or finished floors, sized to accommodate the raceway.
- B. Use care in piercing waterproofing. After the part piercing the waterproofing has been set in place, seal opening and make completely watertight.
- C. Provide chrome-plated spring-clipped escutcheon plates where exposed pipe passes through finished walls, floors or ceilings. Cover sleeves and entire opening made for the pipe with escutcheon plates. Provide air and watertight conduit openings through floor slabs, masonry walls and continuous partitions. Tightly caulk space between conduit and building materials with non flammable sealant.

3.15 Access

- A. Equipment, valves and devices shall be mounted in a manner which provides adequate maintenance, inspection access and work space. Where access is required for adjustment, cleanout, inspection of maintenance and such access is not otherwise available, access panels shall be furnished and installed by Division 26.

3.16 Cleaning of Equipment and Removal of Rubbish

- A. All fixtures, panelboards, motors and all other electrical equipment furnished or installed by the Contractor shall be thoroughly cleaned. At the completion of his work, the Contractor shall remove from the buildings and the premises all rubbish and debris resulting from his operations and shall leave all material and equipment furnished by him and the space occupied by them absolutely ready for use.
- B. Under no circumstances shall rubbish be allowed to accumulate in the building or on the premises. All dirt and rubbish resulting from the Contractor's work shall be removed by this Division from time to time and as often as directed by the Engineer and Owner's representative.

3.17 Tests

- A. The entire system shall be tested, demonstrated and explained to such personnel as the Engineer shall designate. The Contractor will be required to make the following checks and tests with his instruments as required:
 - 1. Motors shall be checked for proper direction of rotation and corrected if necessary.
 - 2. Grounds shall be checked and the resistance to ground shall not be more than 10 Ohms.
 - 3. This Contractor shall balance phase currents of all distribution panelboards within +/-10 percent variation between average phase currents and measured individual phase currents.

3.18 Guarantee

- A. The Contractor shall guarantee by his acceptance of this Contract that all work installed will be free from any and all defects in workmanship and/or materials and that all apparatus will develop capacities and characteristics specified. If, during a period of one year, or as otherwise specified, from date of Certificate of Completion and acceptance of work, any such defect in workmanship, material or performance appears, the Contractor will without cost to the Owner, remedy such defects within a reasonable time as specified in notice from the Engineer. In default thereof, the Owner may have work performed and charge the total cost to the Contractor.

3.19 Maintenance Schedule and Operating Instructions

- A. After the project is completed, Contractor shall be required to furnish four (4) copies of instruction sheets to the Owner for the proper maintenance of electrical equipment and systems furnished and installed by him.
- B. The Contractor shall be required to instruct Owner's operating personnel in the proper operation of electrical systems.
- C. Contractor shall turn over to the Owner all spare parts furnished by manufacturer and those specifically called for in the Specifications. All spare parts shall be properly identified as to the catalog number, manufacturer and the equipment for which they are used.

3.20 Manufacturer's Guarantee and Warranty

- A. Manufacturer's equipment guarantee shall be obtained for at least one year. When manufacturer's standard guarantee is for a longer period, or if longer period is called for in the Specifications, this period shall apply and such items, if

defective, shall be replaced in accordance with the terms written in the manufacturer's specifications.

- B. Manufacturer's certificates of warranty shall be provided for all major pieces of equipment and such written certificates shall be turned over to the Owner prior to the final acceptance of the Project.

3.21 Electrical Circuitry for Equipment

- A. The electrical circuits, components, and controls for all equipment are selected and sized, based on the equipment specified. If substitutions and/or equivalent equipment are furnished, it shall be the responsibility of all parties concerned, involved in, and furnishing the substitute and/or equivalent equipment to verify and compare the electrical characteristics and requirements of that furnished to that specified and/or shown. If greater capacity or more materials or labor is required for the rough-in, circuitry or connections than for the item specified and provided for, then it shall be the responsibility of the parties involved in providing the substitute and/or equivalent items of equipment to provide all compensation for additional charges made for the proper rough-in, circuitry and connections for the equipment furnished. No additional charges shall be made to the Base Bid price or to the Owner.
- B. Before rough-in of circuitry or connecting to equipment, the Contractor shall verify the electrical characteristics and requirements of the equipment being furnished, and for that specified and shown on drawings.

3.22 Operating Instructions and Maintenance Data

- A. Upon completion and acceptance of the work by the Owner, the Contractor shall provide four (4) sets of 8 1/2" x 11" typed operating and maintenance instructions. Sample maintenance instructions will be provided by Engineer upon request. Contractor shall also include wiring diagrams of all controls in each set of maintenance instructions.

END OF SECTION

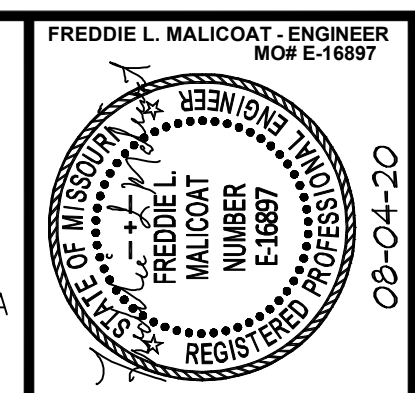

MALICOAT - WINSLOW ENGINEERS, P.C.

MISSOURI STATE CERTIFICATE OF AUTHORITY #000421
5649 N. CLEARVIEW ROAD, COLUMBIA, MISSOURI 65202
TEL 573-875-1300 FAX 573-875-1305
FREDDIE MALICOAT, P.E.

COLUMBIA GOVERNMENT CENTER

701 E. BROADWAY
BOONE COUNTY, COLUMBIA, MO 65201

CONTRACTOR SHALL CHECK & VERIFY ALL DIMENSIONS & CONDITIONS AT JOB SITE.
DATE: 08-04-20

TITLE: **FRAMING DETAILS**
SHEET: **ME1 OF ME2**
PROJECT: 20008

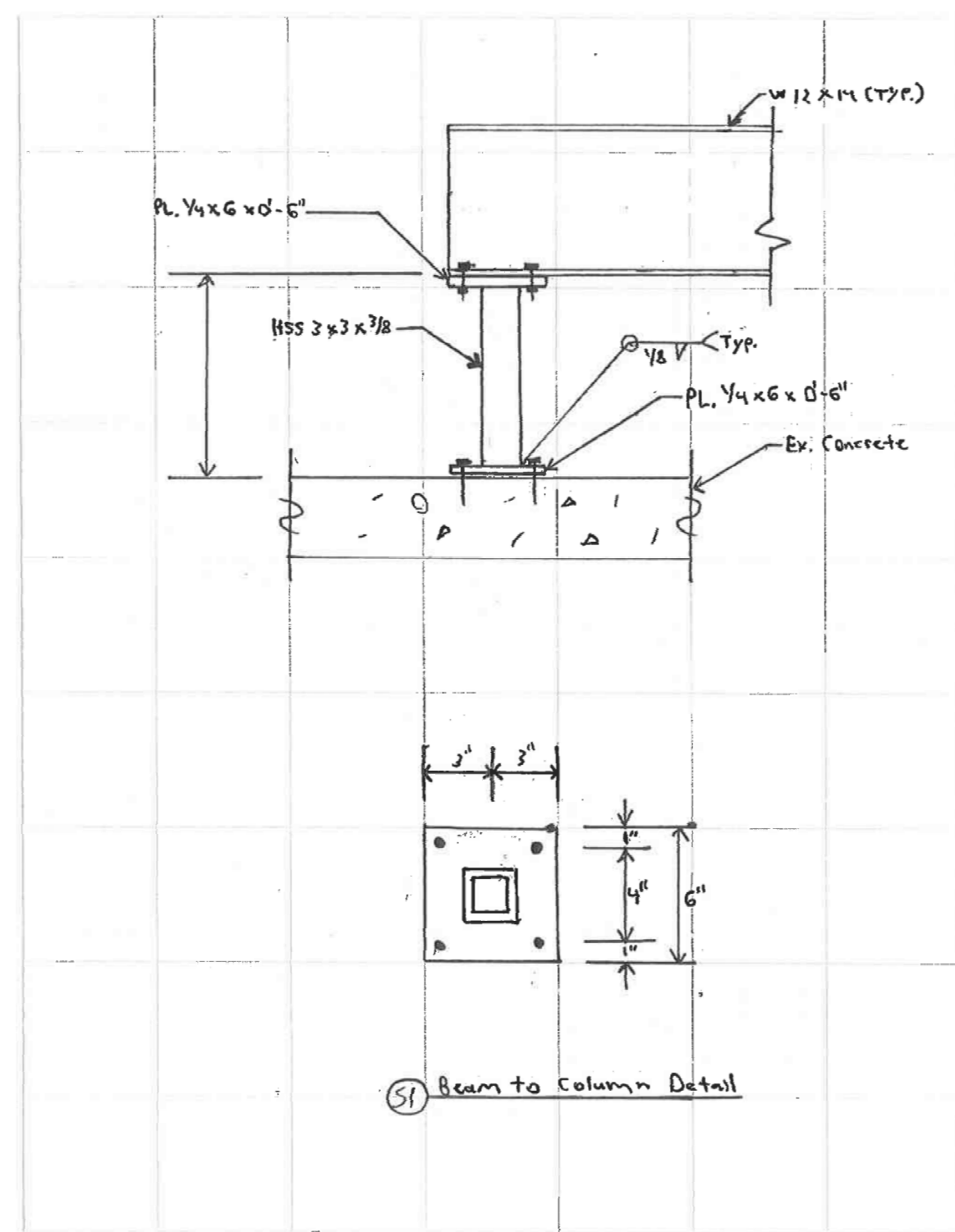

1 BEAM TO COLUMN FRAMING
ME1 SCALE: NO SCALE

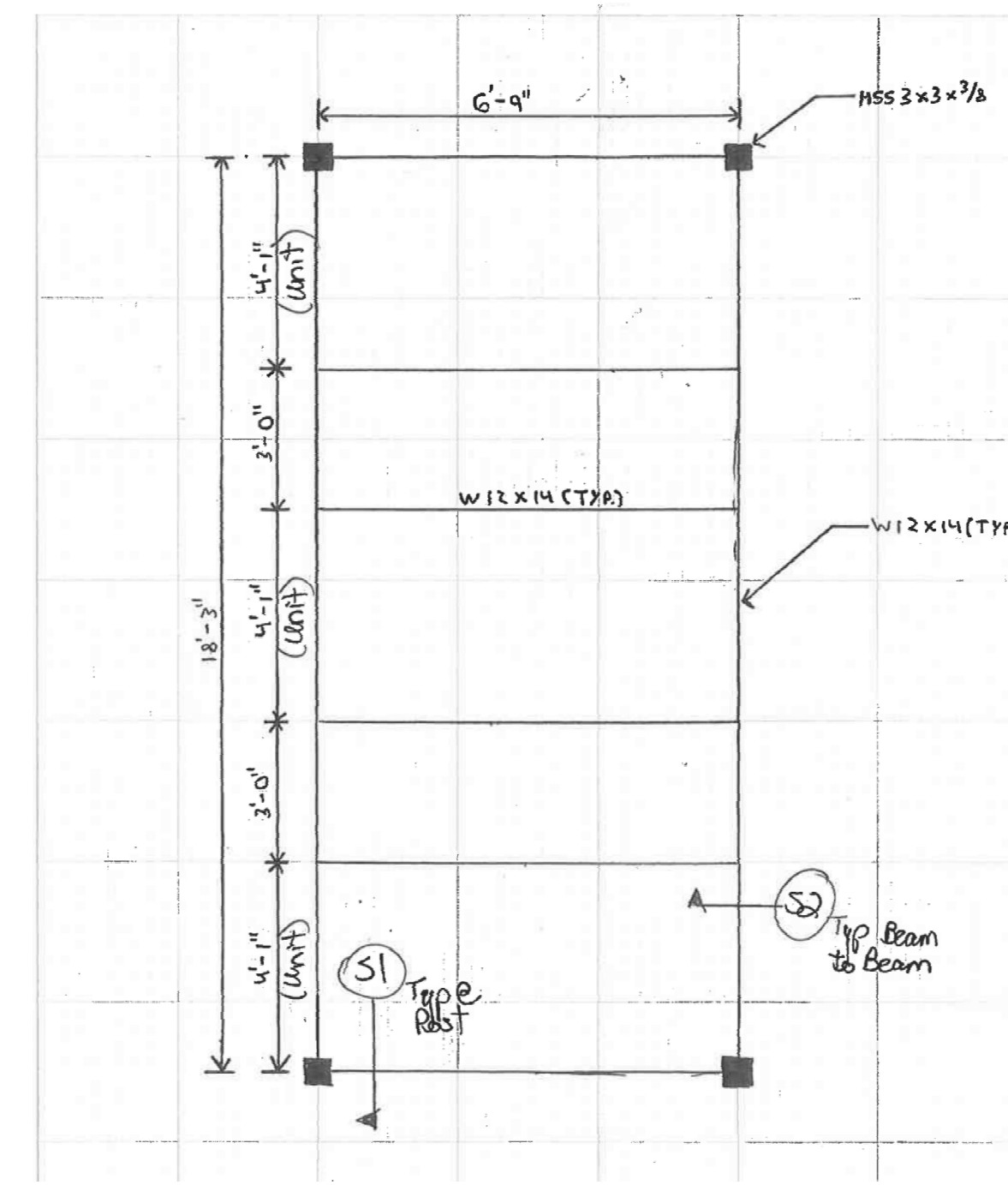

2 MECHANICAL OPENING FRAMING
ME1 SCALE: NO SCALE

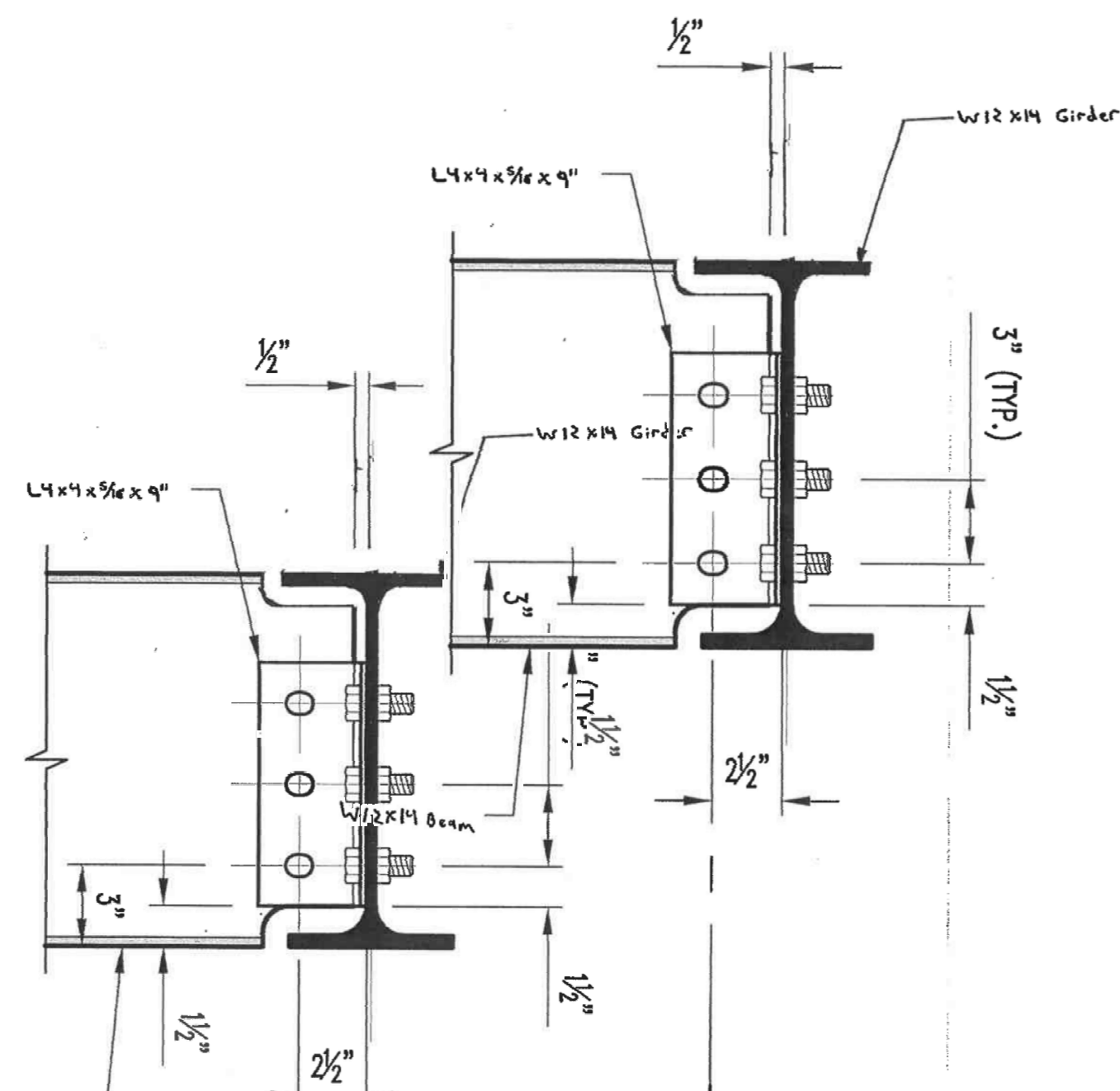

3 BEAM TO BEAM CONNECTION
ME1 SCALE: NO SCALE

2" (TYPICAL)

A
B
C
D
E
F
G
H
I
J
K

1 2 3 4 5 6 7 8 9 10 11 12 13 14 15 16

1 2 3 4 5 6 7 8 9 10 11 12 13 14 15 16

T:\p02020008\20008.dwg, 8/4/2020 11:58:36 AM, zachm

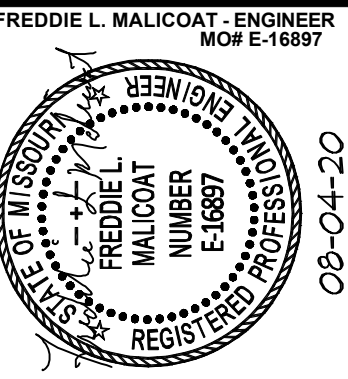

MALICOAT - WINSLOW ENGINEERS, P.C.
 MISSOURI STATE CERTIFICATE OF AUTHORITY #000421
 5649 N. CLEARVIEW ROAD, COLUMBIA, MISSOURI 65202
 TEL: 573-875-1300
 FAX: 573-875-1305
 FREDDIE MALICOAT, P.E.

COLUMBIA GOVERNMENT CENTER
 701 E. BROADWAY
 BOONE COUNTY, COLUMBIA, MO 65201

CONTRACTOR SHALL CHECK & VERIFY ALL DIMENSIONS & CONDITIONS AT JOB SITE.
 DATE: 08-04-20

REVISIONS:

TITLE: DATA
 DEMO HVAC PLAN
 SHEET: ME2
 PROJECT: 20008

DEMOLITION PLAN
 ALTERNATE # 1

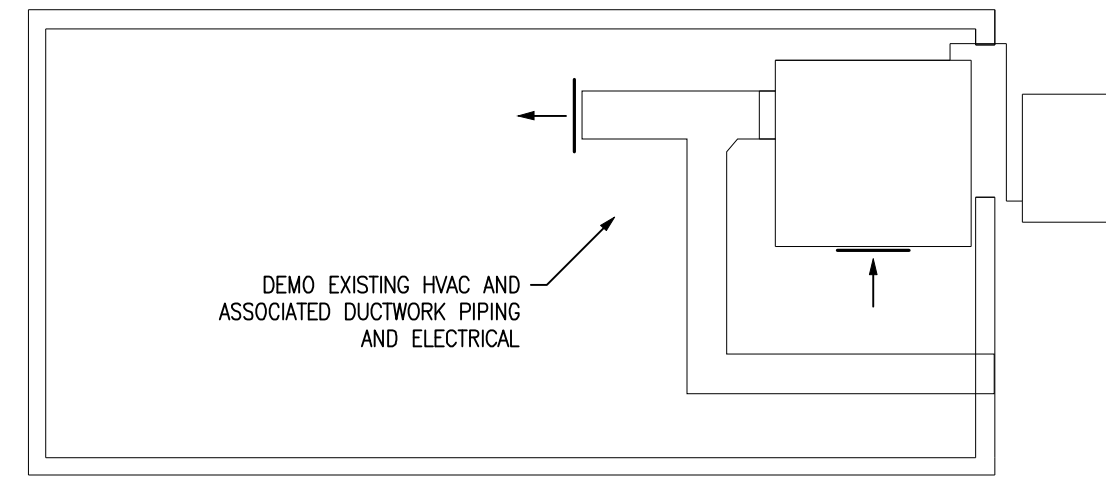

6 FLOOR PLAN - BASEMENT
 ME2 SCALE: 1/4" = 1'-0"

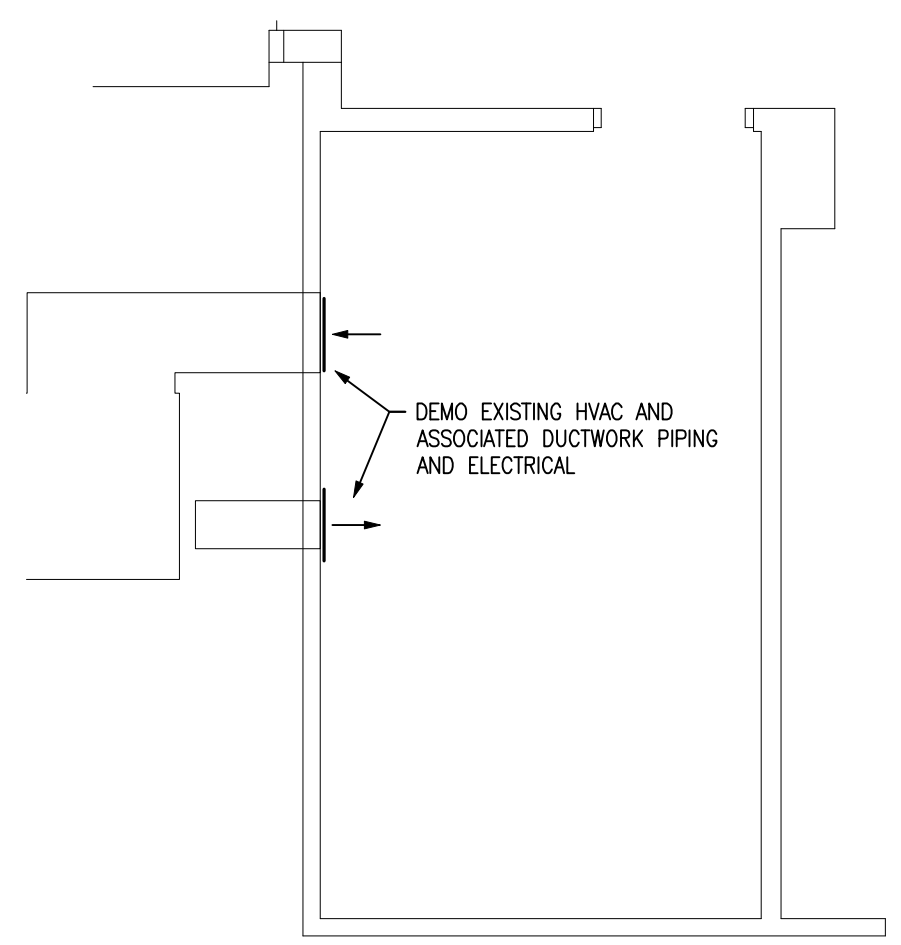

1 FLOOR PLAN 1ST FLR
 ME2 SCALE: 1/4" = 1'-0"

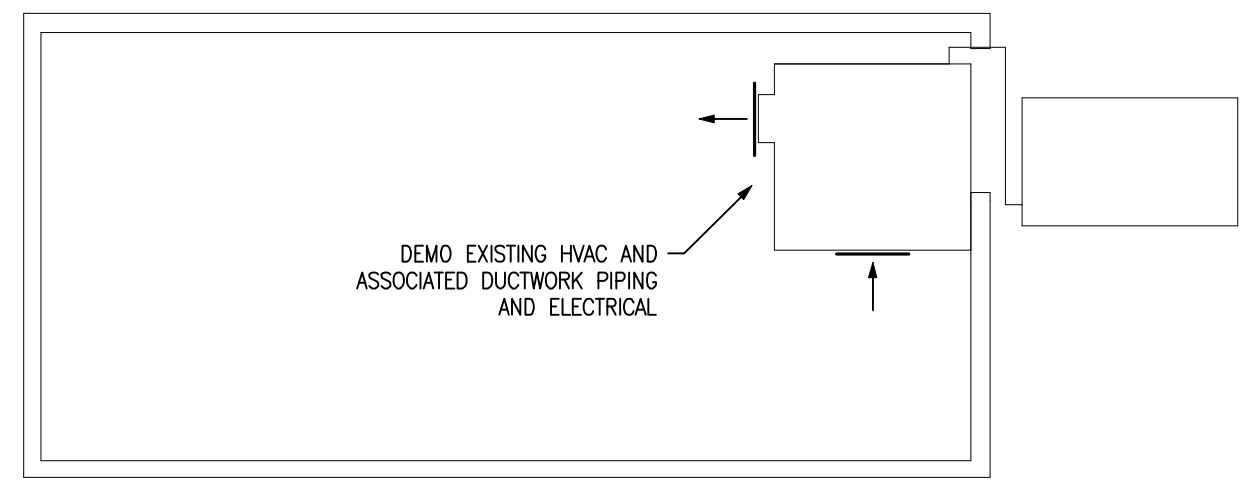

2 FLOOR PLAN 2ND FLR
 ME2 SCALE: 1/4" = 1'-0"

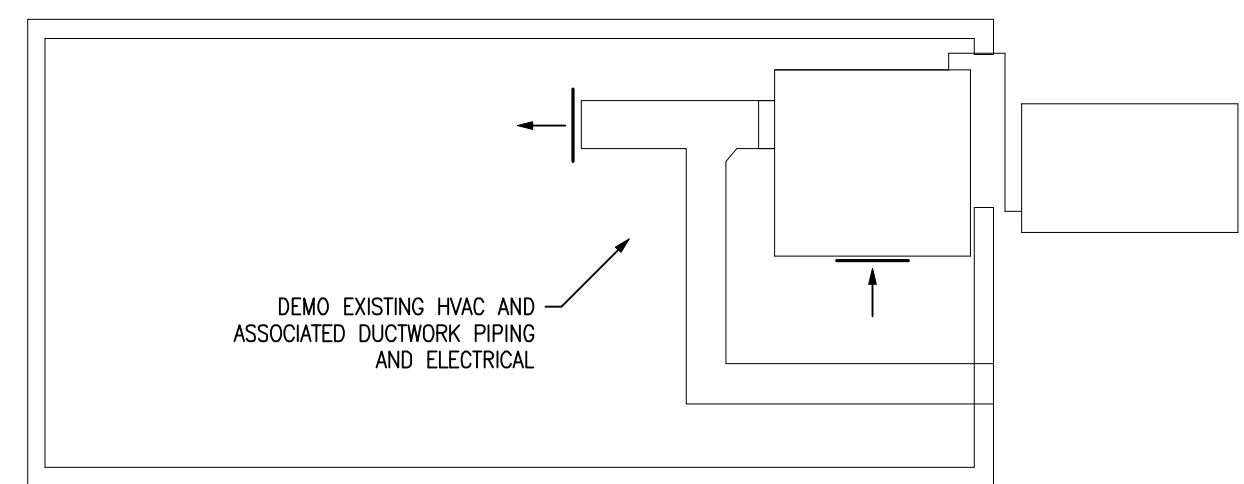

3 FLOOR PLAN 3RD FLR
 ME2 SCALE: 1/4" = 1'-0"

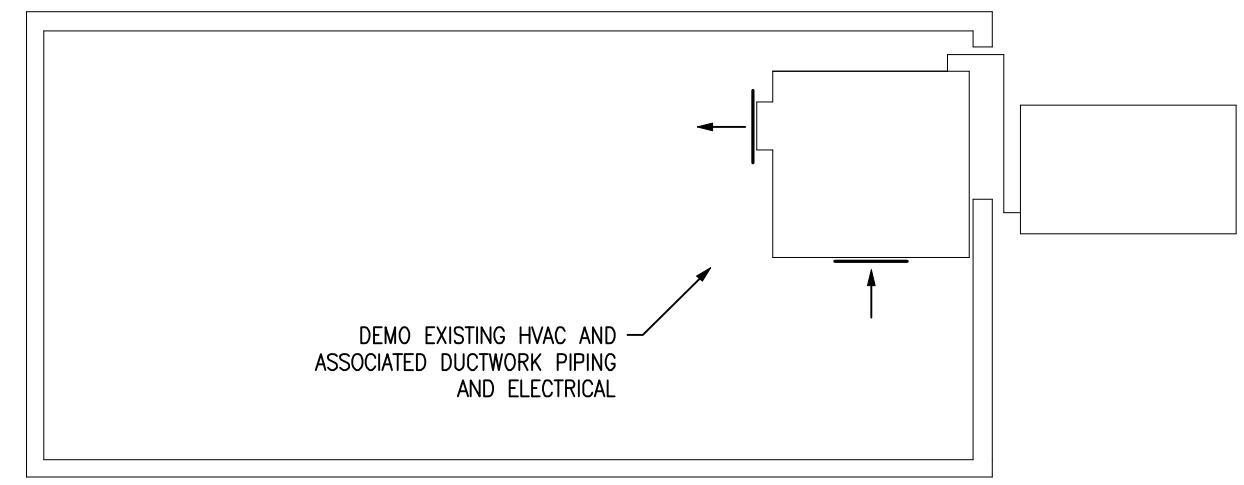

4 FLOOR PLAN 4TH FLR
 ME2 SCALE: 1/4" = 1'-0"

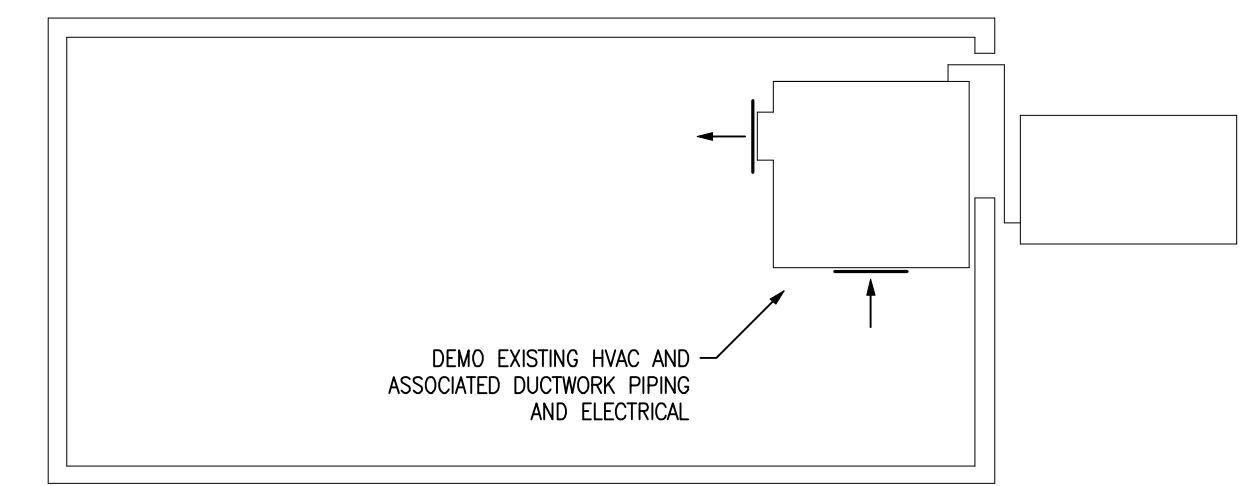

5 FLOOR PLAN 5TH FLR
 ME2 SCALE: 1/4" = 1'-0"

T:\p020008\0008.dwg, 8/4/2020 11:58:54 AM, zachm

MECHANICAL SYMBOL SCHEDULE

c	A/C CONDENSATE LINE
RL	REFRIGERANT LIQUID
RHG	REFRIGERANT HOT GAS
AIR TERMINAL TAG. "A" INDICATES MARK ON GRILLE AND REGISTER SCHEDULE.	
"200" INDICATES AIR VOLUME IN CFM. "12x12" INDICATES FACE SIZE.	
	FIRE DAMPER
	THERMOSTAT

HVAC EQUIPMENT SCHEDULE

APC UNITS										
MARK	-	-	TOTAL CLG	SENS CLG	CFM @ 0.5"	V / #	FLA	MOCF	MODEL	REMARKS
CRAC	-	-	95,000	71,250	3,167	480 / 3	-	40	ACRD601	1
CU	-	-	-	-	-	-	-	15	ACCD75235	1

JENCO VENTILATION FANS											
MARK	CFM	ESP	DRIVE	RPM	SONES	HP	V / #	WATTS	MOCF	MODEL	REMARKS
WF1	640	0.375"	DIRECT	3,200	3.3	-	120 / 1	264	15	TD-MIXVENT - MCA250	

1. FURNISHED BY OWNER AND INSTALLED BY CONTRACTOR.

GRILLE AND REGISTER SCHEDULE

MARK	MFG / MODEL	DAMPER	COLOR	DESCRIPTION
A	PRICE / 5200	YES	WHITE	WALL MOUNT STEEL DOUBLE DEFLECTION SUPPLY REGISTER.

NOTE: ALL GRILLES, REGISTERS, AND DIFFUSERS TO BE ALL ALUMINUM UNLESS NOTED OTHERWISE. STEEL CAN BE USED IF POWDER COATED PAINT IS APPLIED. QUANTITIES, SIZES, FRAMES AND ACCESSORIES TO BE CONFIRMED BY CONTRACTOR.

- ### GENERAL NOTES:
1. VERIFY PLUMBING, HVAC, AND POWER REQUIREMENTS FOR OWNER'S SPECIFIC EQUIPMENT PRIOR TO ROUGH-IN.
 2. COORDINATE INSTALLATION OF EQUIPMENT WITH MANUFACTURERS' INSTALLATION INSTRUCTIONS PRIOR TO ROUGH-IN.
 3. CONTRACTOR SHALL MAINTAIN FIRE RATING OF ANY PENETRATION AND SHALL SEAL ANY PENETRATION IN A FLOOR, CEILING, OR EXTERIOR WALL.
 4. INSTALL A FIRE DAMPER AT EVERY FIRE RATED ASSEMBLY PENETRATION TO MAINTAIN FIRE RATING OF ASSEMBLY.

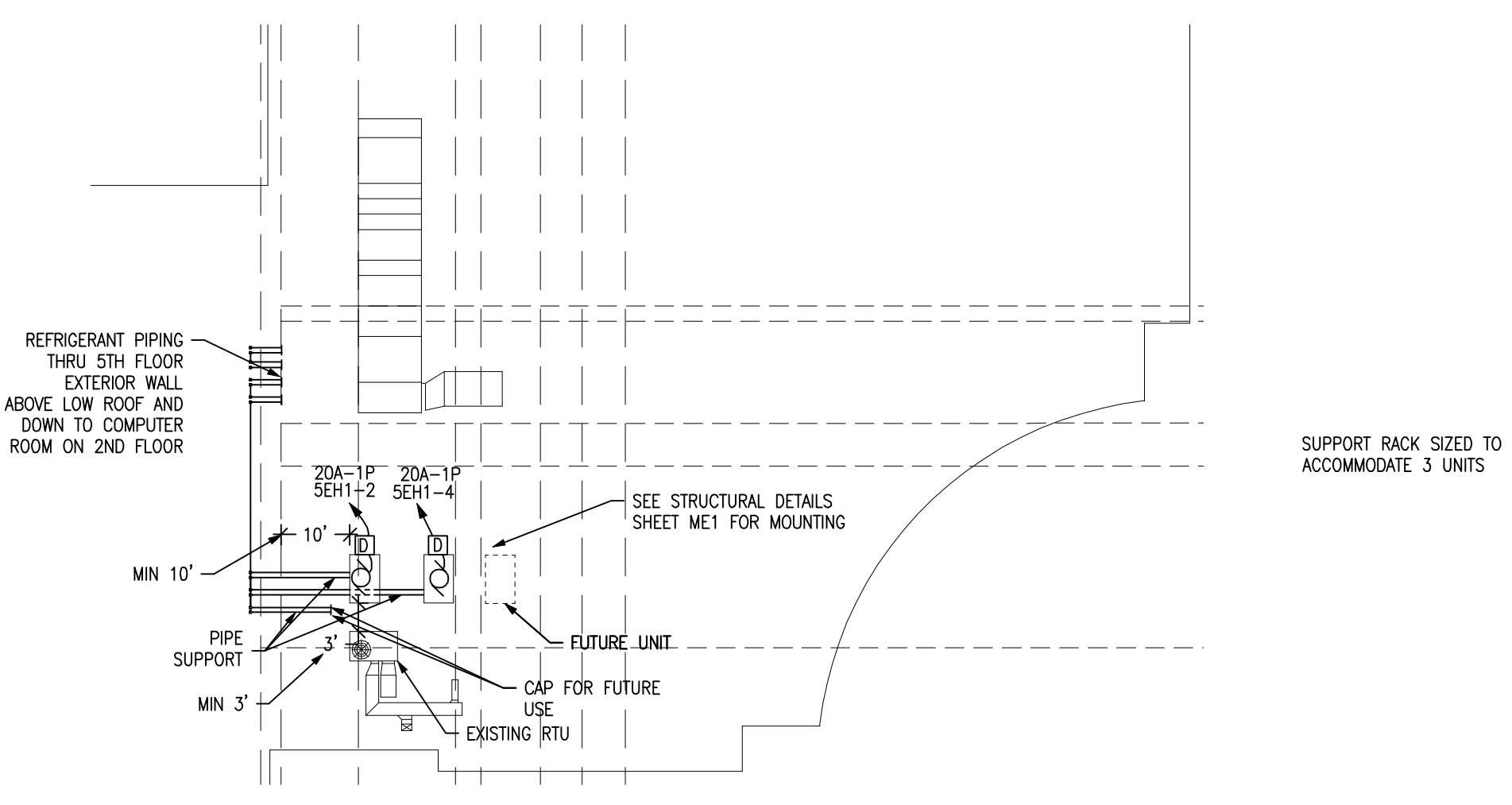

6 PARTIAL ROOF PLAN
SCALE: 1"=20'-0"

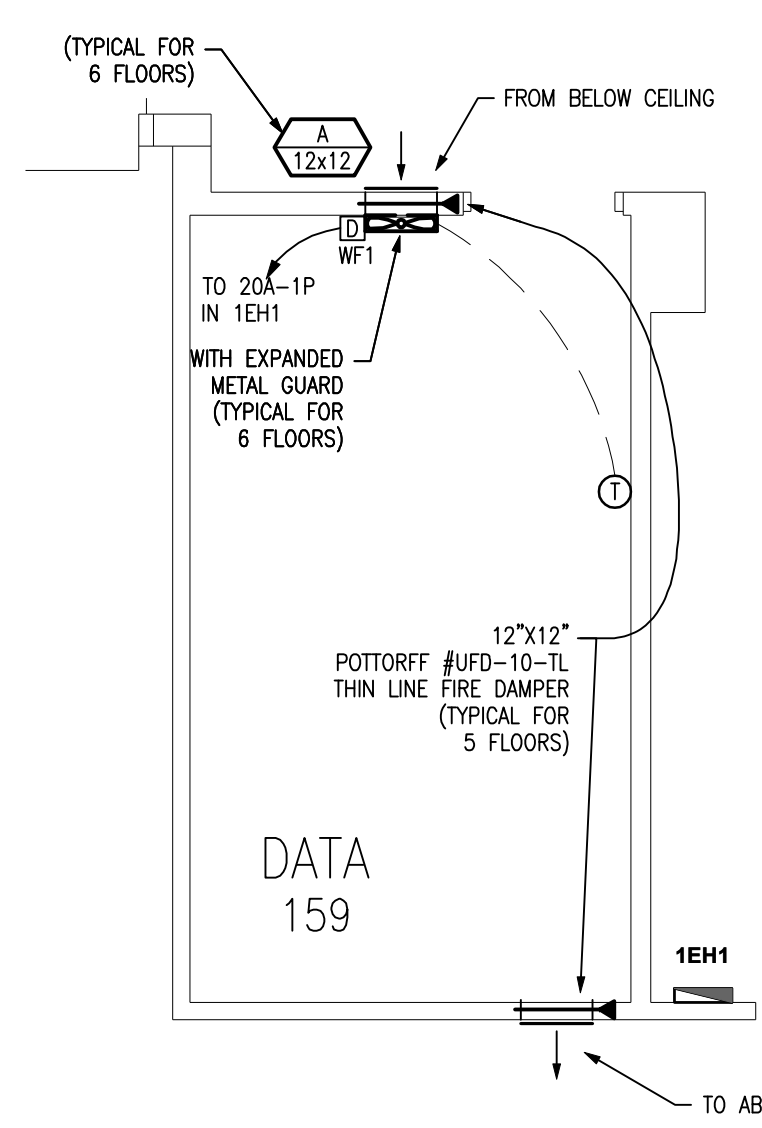

1 FLOOR PLAN 1ST FLR
SCALE: 1/4" = 1'-0"

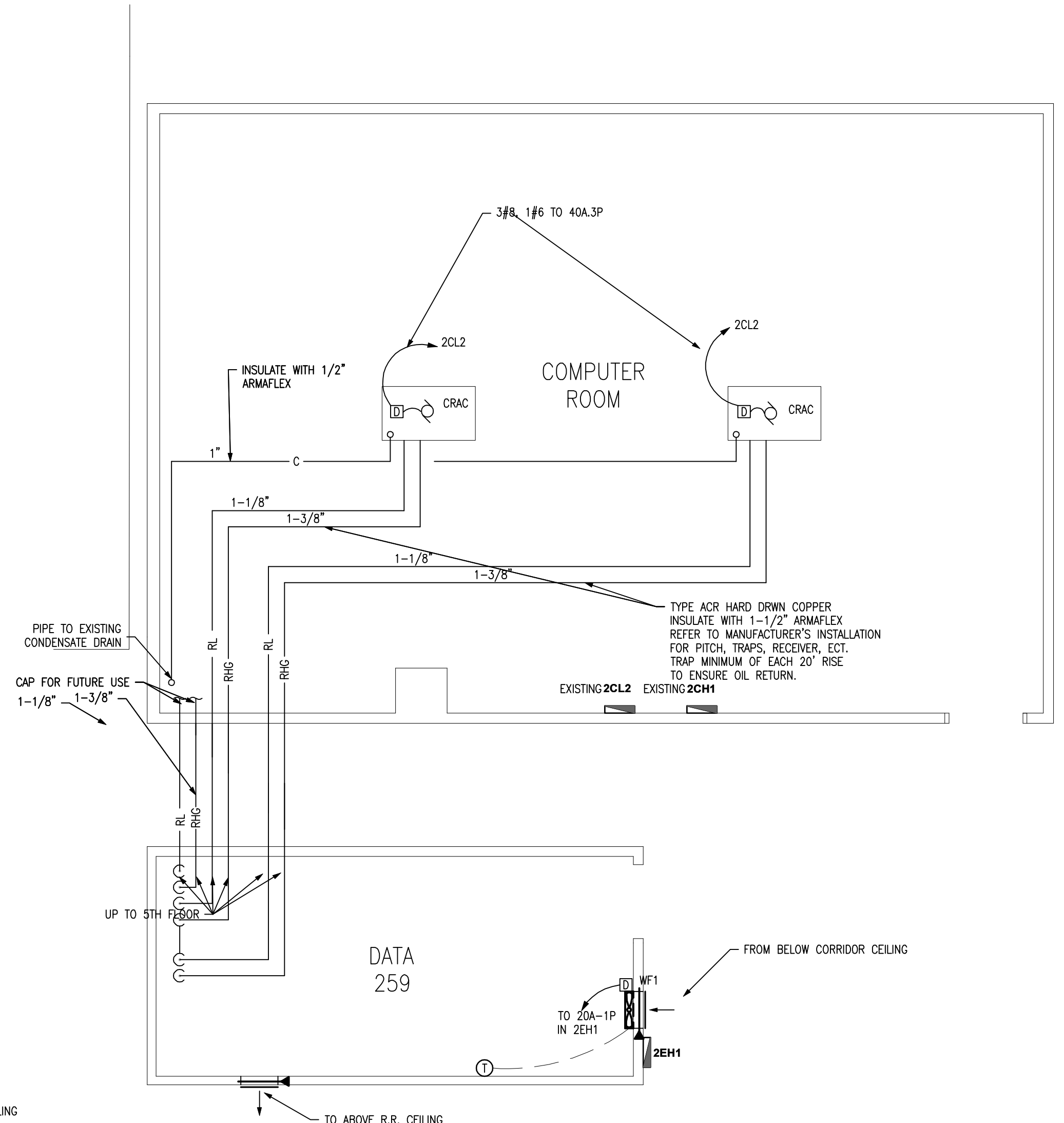

2 FLOOR PLAN 2ND FLR
SCALE: 1/4" = 1'-0"

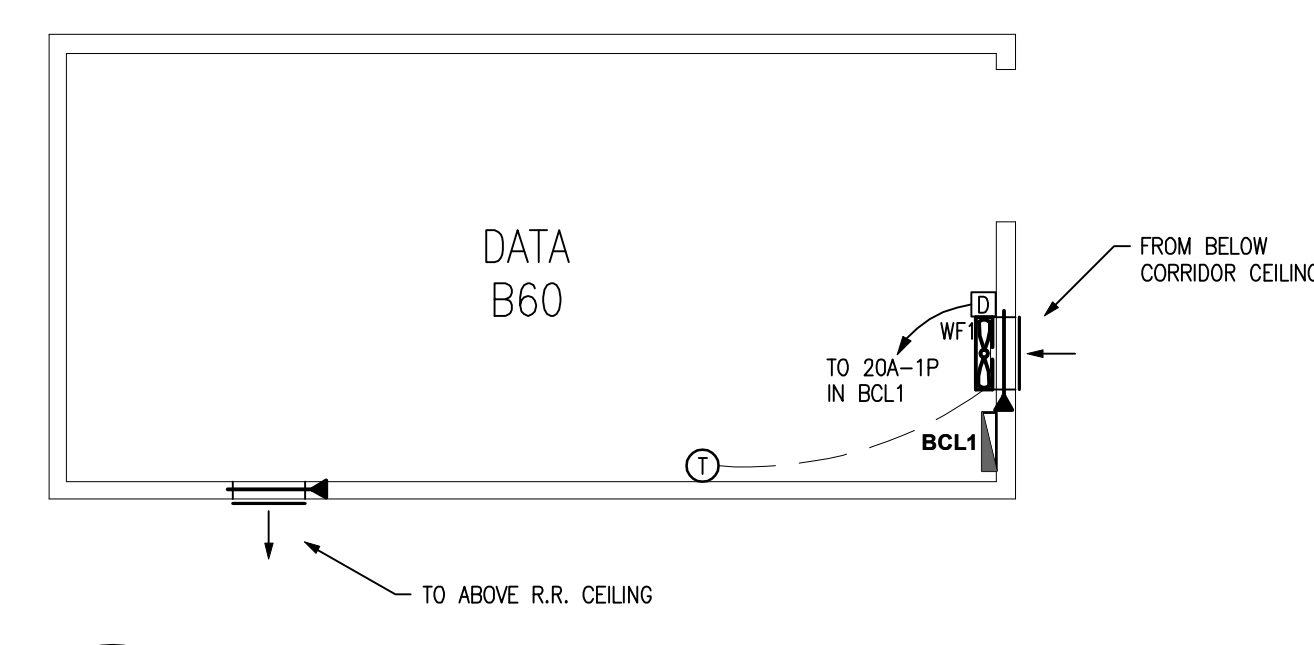

9 FLOOR PLAN - BASEMENT
SCALE: 1/4" = 1'-0"

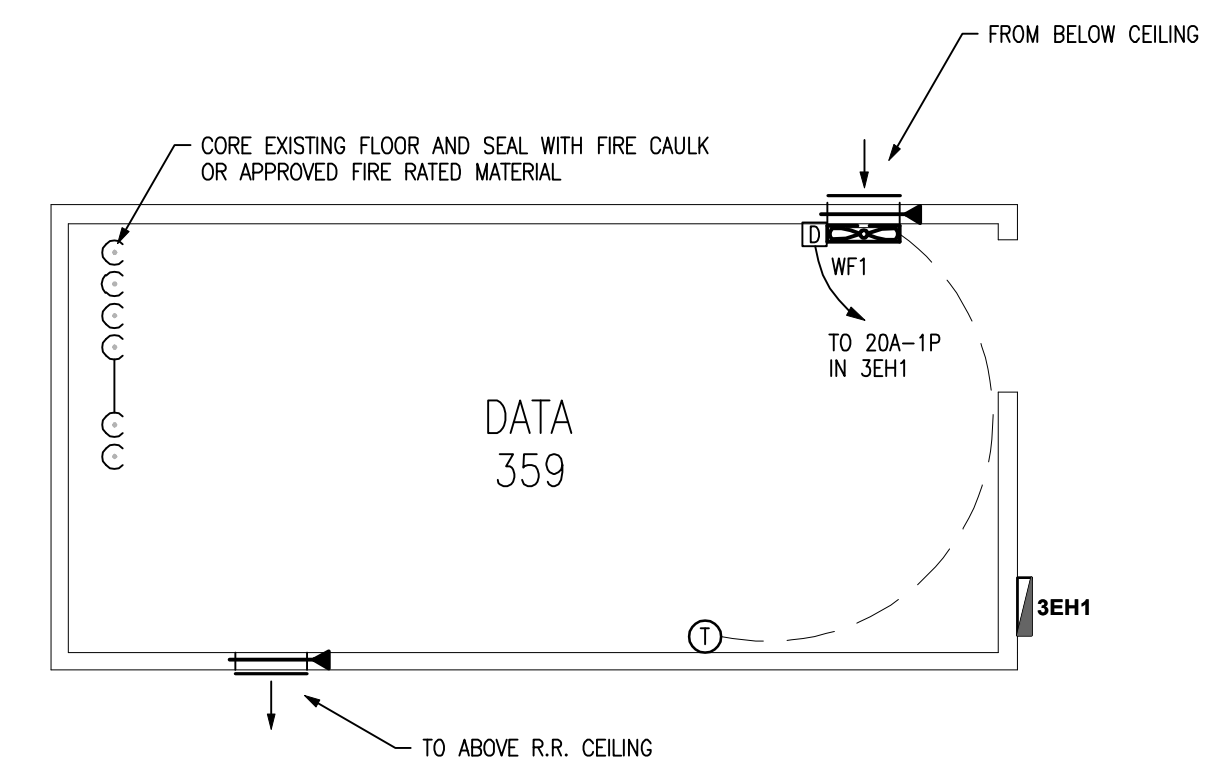

3 FLOOR PLAN 3RD FLR
SCALE: 1/4" = 1'-0"

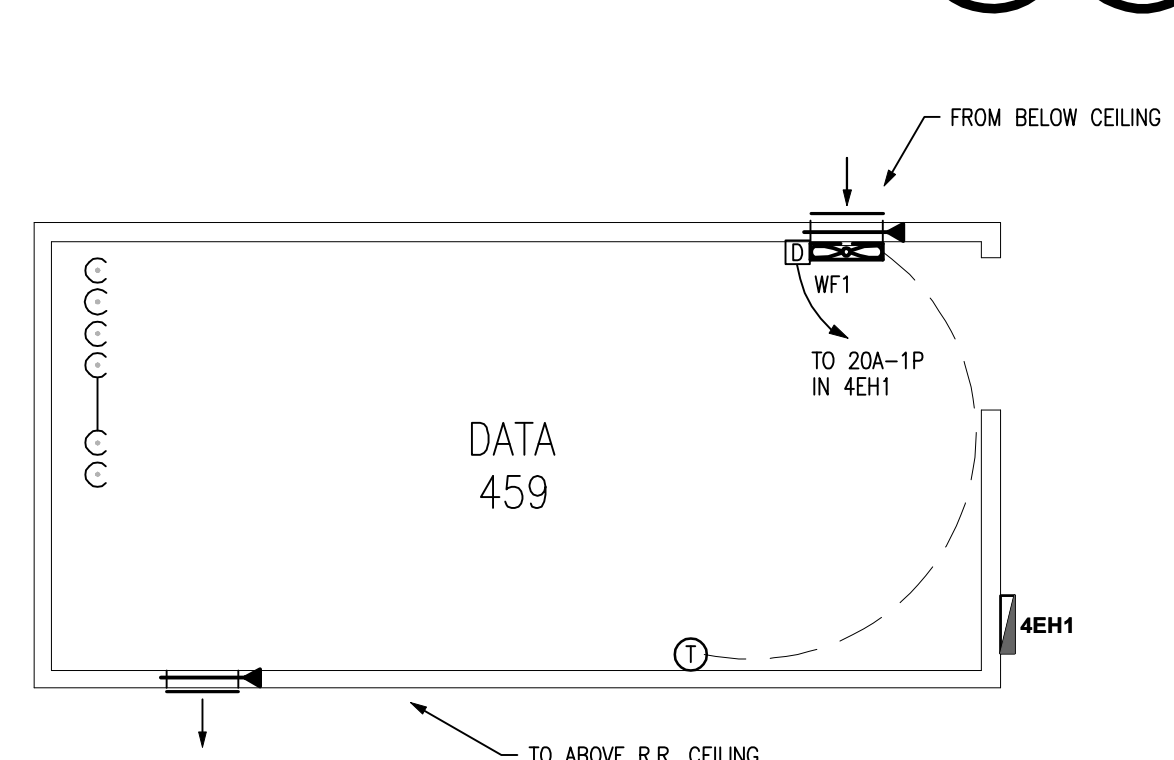

4 FLOOR PLAN 4TH FLR
SCALE: 1/4" = 1'-0"

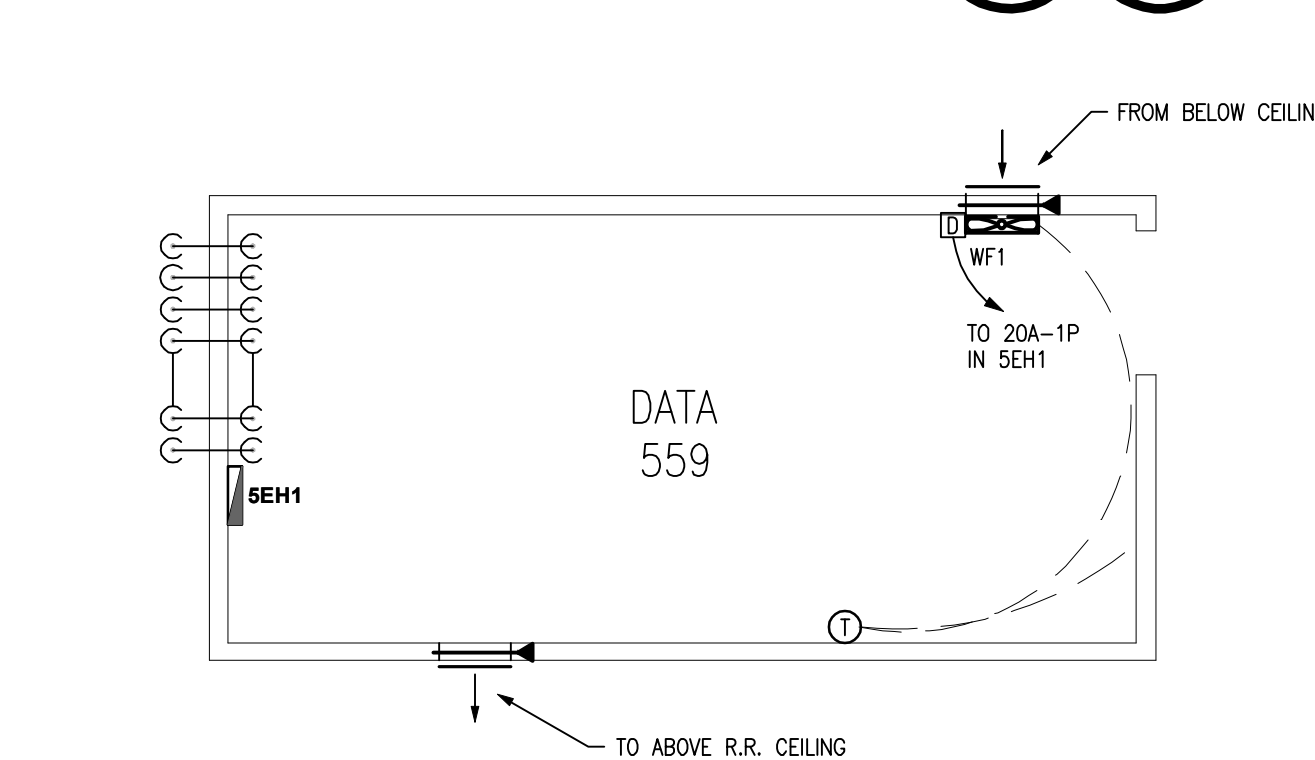

5 FLOOR PLAN 5TH FLR
SCALE: 1/4" = 1'-0"

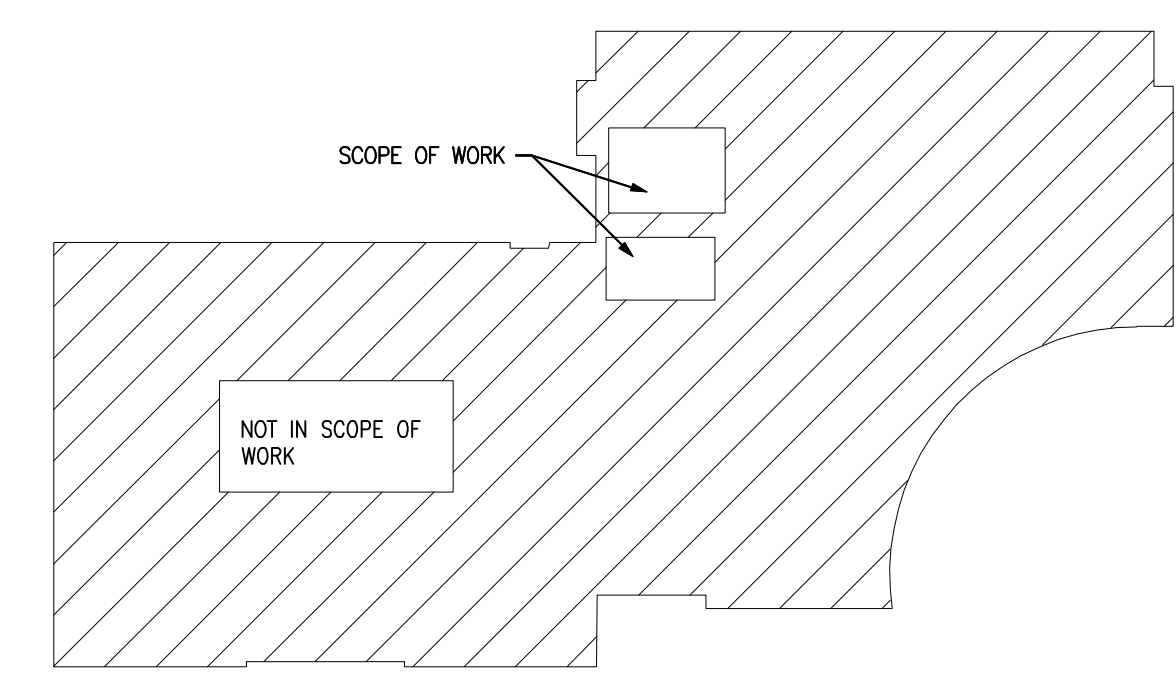

7 KEY PLAN 2ND FLR
SCALE: NO SCALE

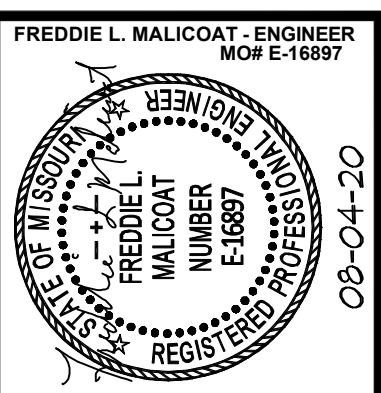

MALICOAT - WINSLOW ENGINEERS, P.C.
MISSOURI STATE CERTIFICATE OF AUTHORITY #000421
5649 N. CLEARVIEW ROAD, COLUMBIA, MISSOURI 65202
TEL 573-875-1300 FAX 573-875-1305
FREDDIE MALICOAT, P.E.

COLUMBIA GOVERNMENT CENTER
701 E. BROADWAY
BOONE COUNTY, COLUMBIA, MO 65201

CONTRACTOR SHALL CHECK & VERIFY ALL DIMENSIONS & CONDITIONS AT JOB SITE.
DATE: 08-04-20

TITLE: DATA HVAC PLAN

SHEET: M1 of M1
PROJECT: 20008

T:\p02020008\0008.dwg, 8/4/2020 11:58:31 AM, zachm