

No.	Date	By	Revision

GRINDSTONE SIDEWALK PROJECT
 (HYDE PARK AVE. TO NORFLEET DR.)
 Preliminary Plan Sheet

Mission
 Provide safe, sustainable
 infrastructure that promotes
 positive communities.

701 East Broadway
 P.O. Box 6015
 Columbia, MO 65205
 (573) 875-2489

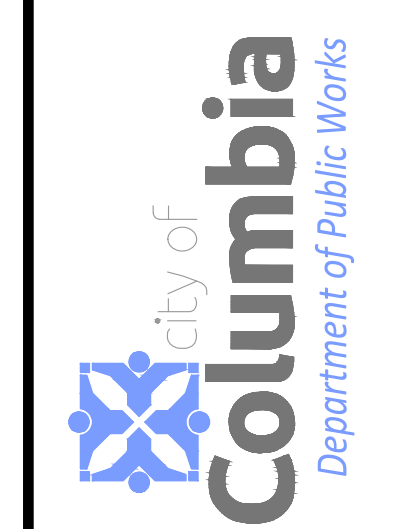

Shane Steven Creach
 Registered Professional
 Engineer
 PE-2007011061

File No. 00820
 Scale: 1"=20'
 Date: 4/24/2023
 Des. E.M.F
 Dwn. A.A.E
 Chk. A.A.A

c:\cadd\proj\sidewalk\grindstone\long_sidewalk_sap\design\grindstone_sidewalk_sap\with_grindstone.dwg

o:\cadd\proj\sidewalk\grindstone-norfleet\sidewalk_spl\design\grindstone_sidewalk_spl.dwg - as with grist.dwg



PL REAL ESTATE, LLC, A MISSOURI LIMITED LIABILITY COMPANY
 1101 E NIFONG BLVD
 COLUMBIA MO 65201
 QUIT CLAIM DEED IN BOOK 4530 PAGE 124
 PARCEL # 17-701-00-00-027.00 01
 TRACT 3
 BOOK 4842 PAGE 47

CITY OF COLUMBIA, MISSOURI, A MUNICIPAL CORPORATION OF THE STATE OF MISSOURI
 GRINDSTONE PARKWAY
 COLUMBIA MO 65201
 WARRANTY DEED IN BOOK 4478 PAGE 61
 PARCEL # 17-701-00-31-001.00 01
 LOT 1
 RED OAK SOUTH PLAT NO. 1
 PLAT BOOK 46 PAGE 32

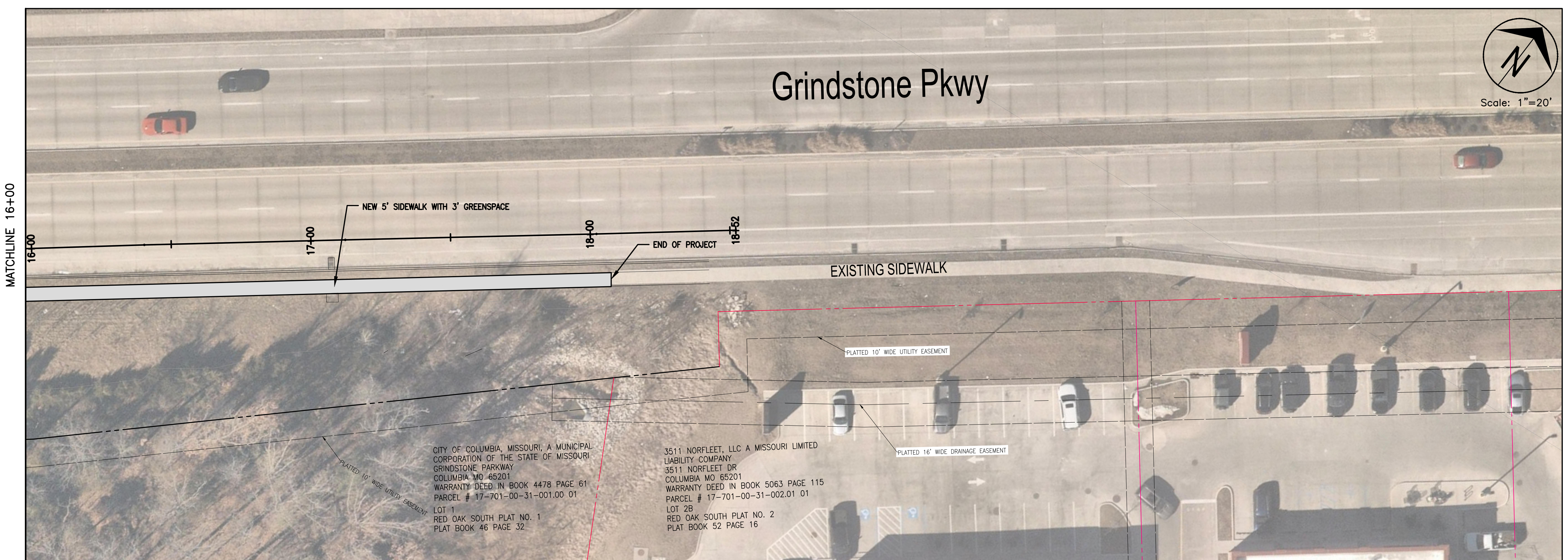

CITY OF COLUMBIA, MISSOURI, A MUNICIPAL CORPORATION OF THE STATE OF MISSOURI
 GRINDSTONE PARKWAY
 COLUMBIA MO 65201
 WARRANTY DEED IN BOOK 4478 PAGE 61
 PARCEL # 17-701-00-31-001.00 01
 LOT 1
 RED OAK SOUTH PLAT NO. 1
 PLAT BOOK 46 PAGE 32

3511 NORFLEET, LLC A MISSOURI LIMITED LIABILITY COMPANY
 3511 NORFLEET DR
 COLUMBIA MO 65201
 WARRANTY DEED IN BOOK 5063 PAGE 115
 PARCEL # 17-701-00-31-002.01 01
 LOT 2B
 RED OAK SOUTH PLAT NO. 2
 PLAT BOOK 52 PAGE 16

No.	Date	By	Revision

GRINDSTONE SIDEWALK PROJECT
 (HYDE PARK AVE. TO NORFLEET DR.)
 Preliminary Plan Sheet

Mission
 Provide safe, sustainable infrastructure that promotes positive communities.

701 East Broadway
 P.O. Box 8015
 Columbia, MO 65205
 (573) 875-2489

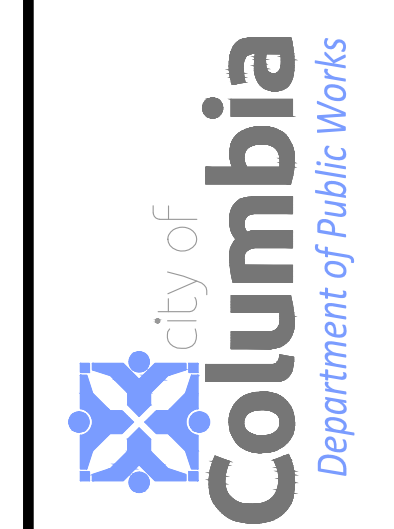

Shane Steven Creesh
 Registered Professional Engineer
 PE-2007011061

File No.	00820
Scale:	1"=20'
Date:	4/24/2023
Des.	E.M.F
Dwn.	A.A.E
Chk.	A.A.A

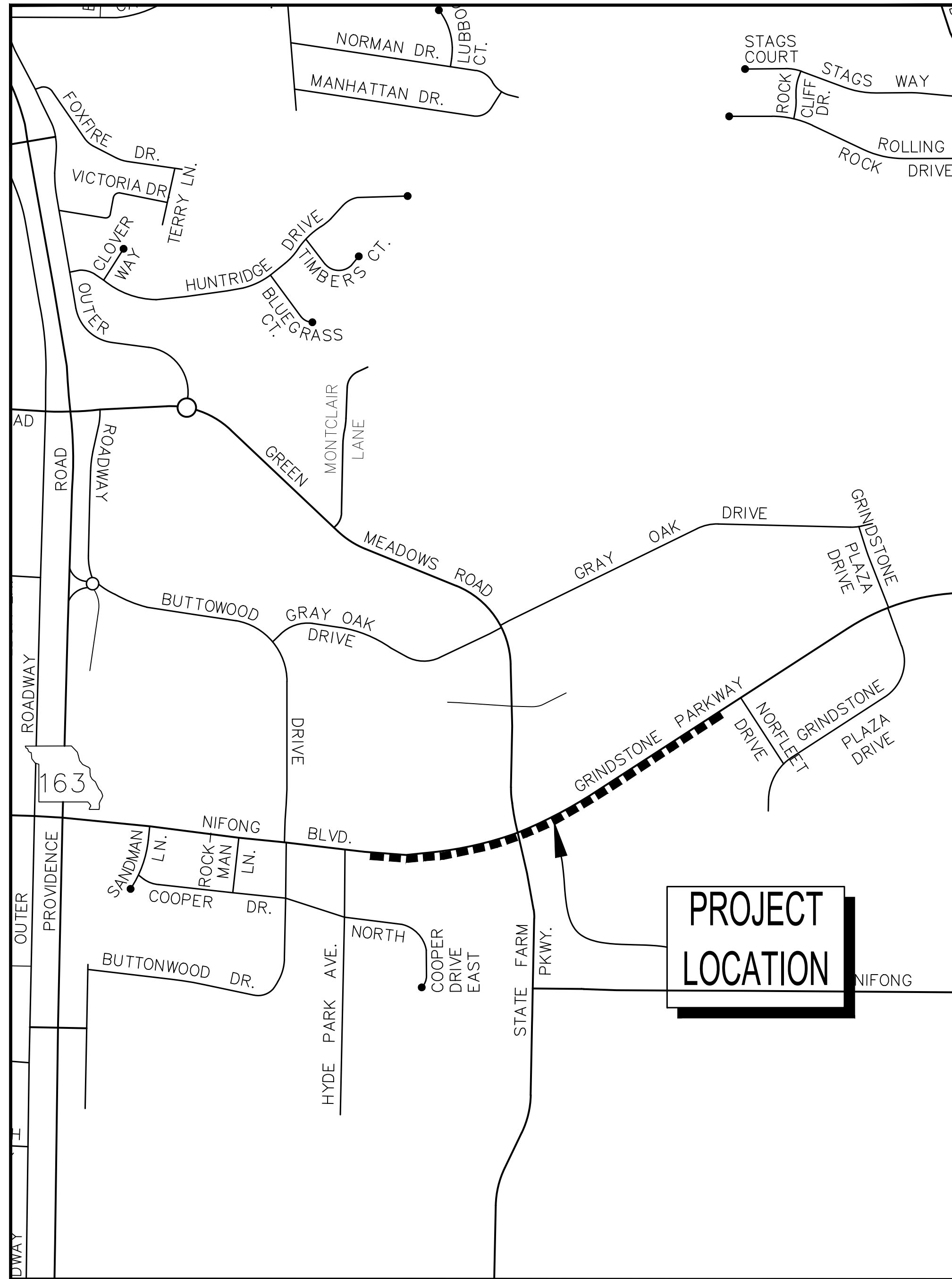

LOCATION MAP
SCALE: 1"=500'

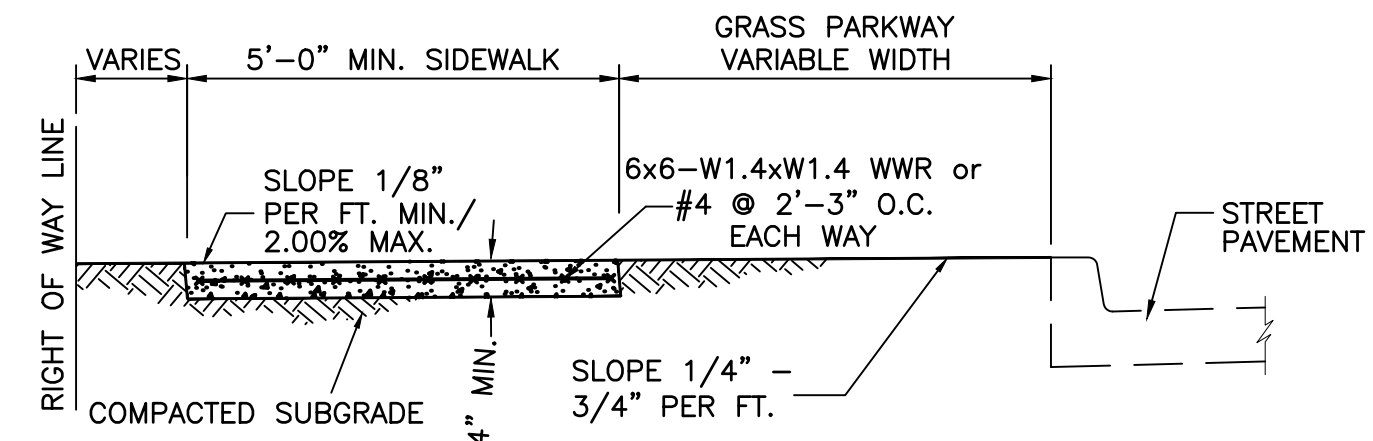
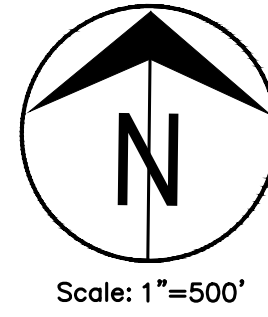

SIDEWALK WITH GRASS PARKWAY
(NOT TO SCALE)

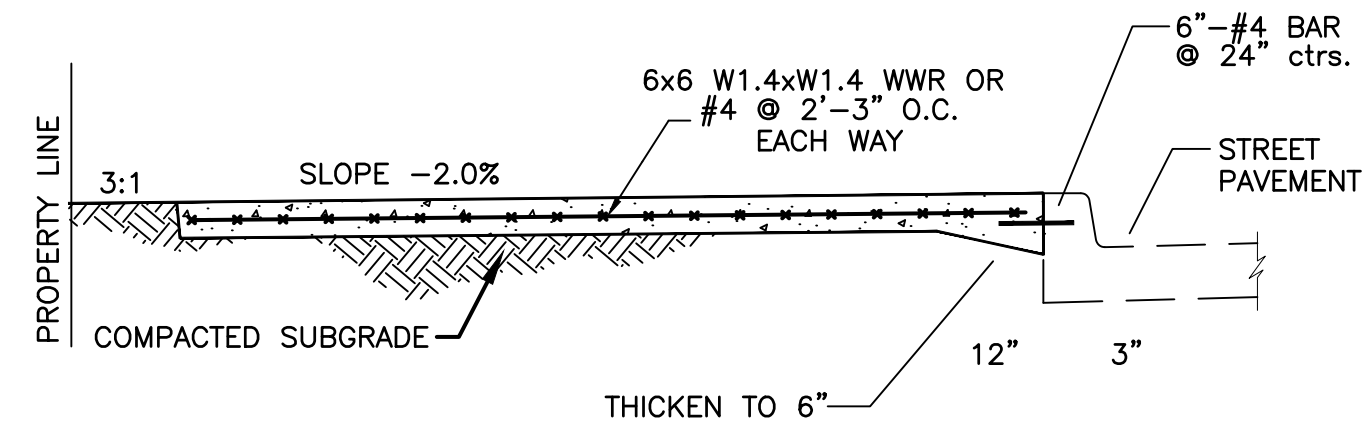

SIDEWALK AT BACK OF CURB
(NOT TO SCALE)

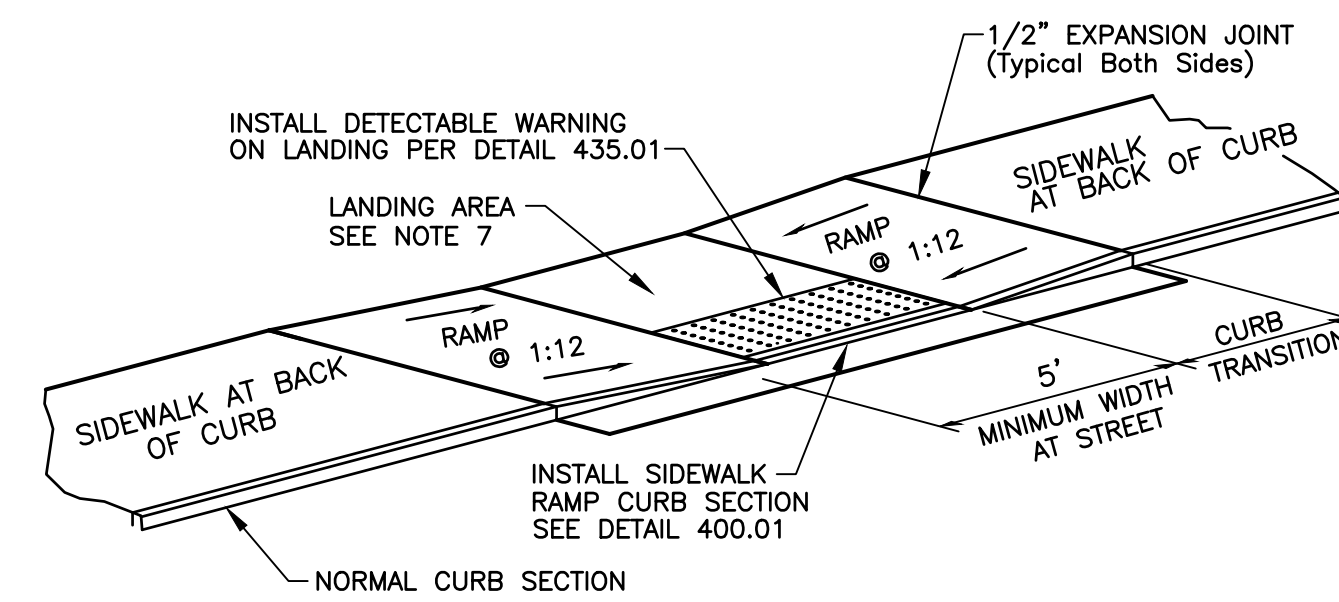

SIDEWALK RAMP AND LANDING
(NOT TO SCALE)

No.	Date	By	Revision

GRINDSTONE SIDEWALK PROJECT
(HYDE PARK AVE. TO NORFLEET DR.)

Preliminary Plan Sheet

Mission
Provide safe, sustainable infrastructure that promotes positive communities.

701 East Broadway
P.O. Box 6015
Columbia, MO 65205
(573) 875-2489



Shane Steven Creech Registered Professional Engineer PE-2007011061
File No. 00820
Scale: None
Date: 4/24/2023
Des. E.M.F
Dwn. A.A.E
Chk. A.A.A

c:\caddpro\sidewalk\grindstone-nifong\sidewalk_gsp\Design\grindstone sidewalk - sw with grass.dwg