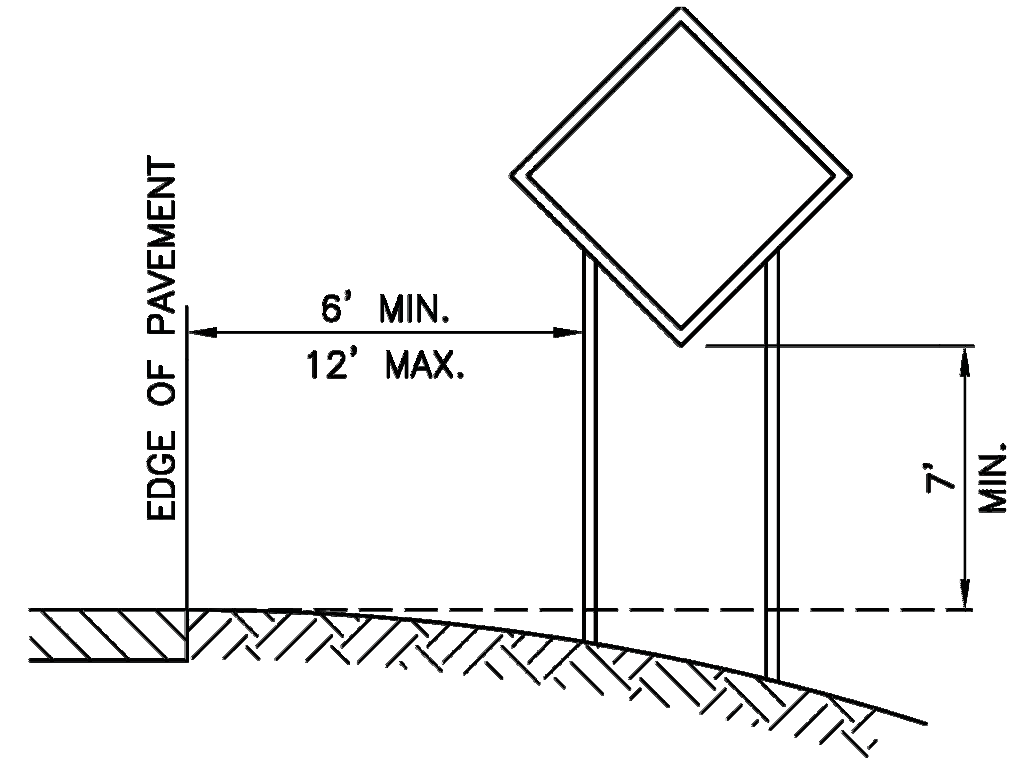
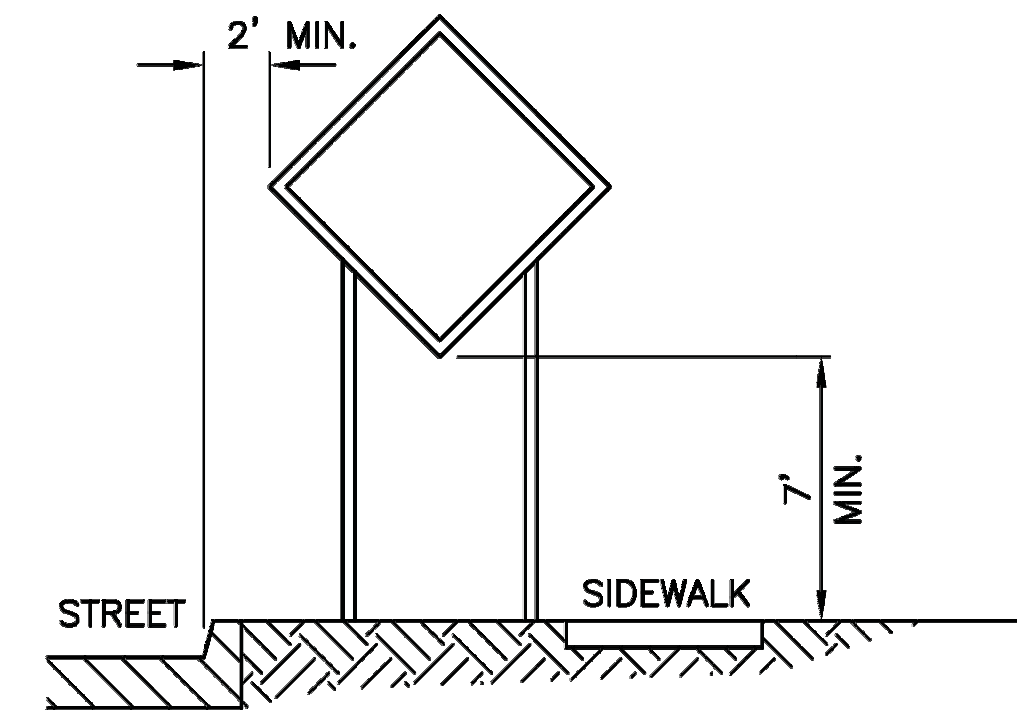

Exhibit A



NOTE: SUPPORT POSTS SHALL NOT EXTEND ABOVE SIGN UNLESS DISTANCE PLAQUE OR WARNING LIGHTS ARE SPECIFIED.

SIGN MOUNTING



NOTE: SUPPORT POSTS SHALL NOT EXTEND ABOVE SIGN UNLESS DISTANCE PLAQUE OR WARNING LIGHTS ARE SPECIFIED.

SIGN MOUNTING

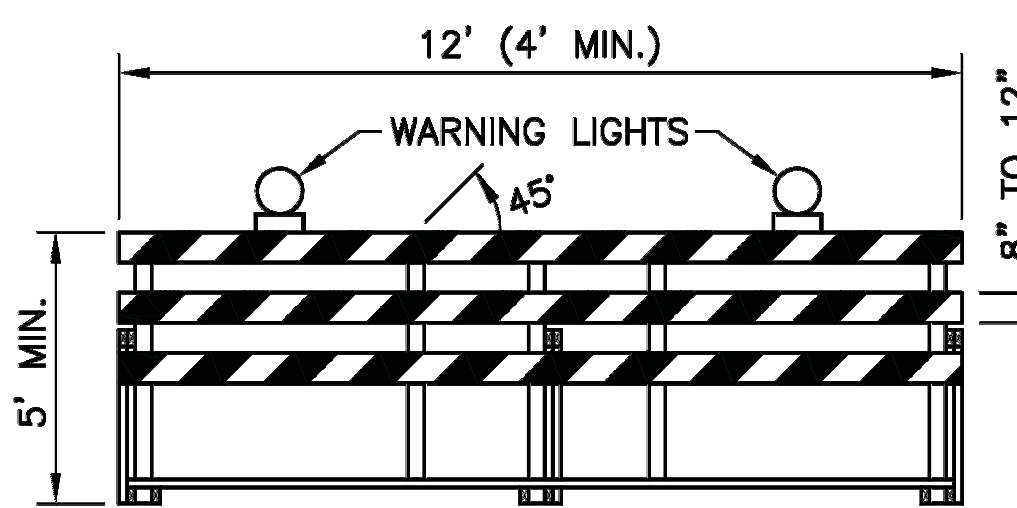

- NOTES:
1. NOMINAL LUMBER DIMENSIONS ARE SATISFACTORY FOR BARRICADE RAIL WIDTH DIMENSIONS.
 2. RAIL STRIPE WIDTHS SHALL BE 6". THE SIDES OF BARRICADES FACING TRAFFIC SHALL HAVE RETROREFLECTIVE RAIL FACES.
 3. ALL TYPE III BARRICADES SHALL HAVE TWO TYPE B WARNING LIGHTS.
 4. STRIPES ON BARRICADE RAILS SHALL BE ALTERNATING ORANGE AND WHITE RETROREFLECTIVE STRIPES SLOPING DOWNWARD AT AN ANGLE OF 45 DEGREES IN THE DIRECTION ROAD USERS ARE TO PASS.

TYPE III BARRICADE

TRAFFIC CONTROL NOTES:

1. IT IS THE RESPONSIBILITY OF THE CONTRACTOR TO INSURE THAT ALL BARRICADES, SIGNS, OTHER TRAFFIC CONTROL DEVICES AND PLACEMENT THEREOF SHALL CONFORM TO THE CURRENT EDITION OF THE MANUAL ON UNIFORM TRAFFIC CONTROL DEVICES (MUTCD).
2. THE CONTRACTOR SHALL NOTIFY CPM OF ALL ROAD CLOSURES OR LAND REDUCTIONS IN ADVANCE.
3. TRAFFIC CONTROL DEVICES TO BE IN PLACE PRIOR TO BEGINNING CONSTRUCTION. ACTUAL QUANTITIES WILL DEPEND ON THE CONTRACTOR'S CONSTRUCTION SEQUENCE AND PROGRESS. NO MEASUREMENT WILL BE MADE OF ACTUAL QUANTITIES. QUANTITIES SHOWN ARE APPROXIMATE.
4. CONTRACTOR SHALL MAINTAIN ACCESS TO ALL PROPERTIES IN THE CONSTRUCTION ZONE TO THE MAXIMUM EXTENT PRACTICABLE.
5. WARNING LIGHTS SHALL FLASH WHEN PLACED ON CHANNELIZING DEVICES USED ALONE OR IN A CLUSTER TO WARN OF A CONDITION. THESE SHALL BE TYPE B.
6. WARNING LIGHTS PLACED ON CHANNELIZING DEVICES USED IN A SERIES TO CHANNELIZE ROAD USERS SHALL BE STEADY-BURN. THESE SHALL BE TYPE C.
7. CONTRACTOR SHALL INSTALL AND MAINTAIN PROJECT SIGN THROUGHOUT CONSTRUCTION CONTRACT. SIGN SHALL BE REMOVED BY CONTRACTOR AT PROJECT COMPLETION.
8. NO OPEN TRENCHES WILL BE ALLOWED OVERNIGHT OUTSIDE OF THE "ROAD CLOSED" AREA. ASPHALTIC "COLD MIX" SHALL BE USED AS A TEMPORARY PATCH OVERNIGHT. TEMPORARY PATCHING SHALL BE CONSIDERED INCIDENTAL TO THE WORK.
9. ALL OPEN TRENCHES ARE TO BE BARRICADED WITH CONSTRUCTION FENCING.
10. SEE G001 AND G002 FOR CONSTRUCTION FENCING & STAGING.
11. FOR ANY CONSTRUCTION ACTIVITIES THAT REQUIRE A STREET LANE TO BE BLOCKED CONTRACTOR IS RESPONSIBLE TO PROVIDE FLAG MEN TO DIRECT TRAFFIC.

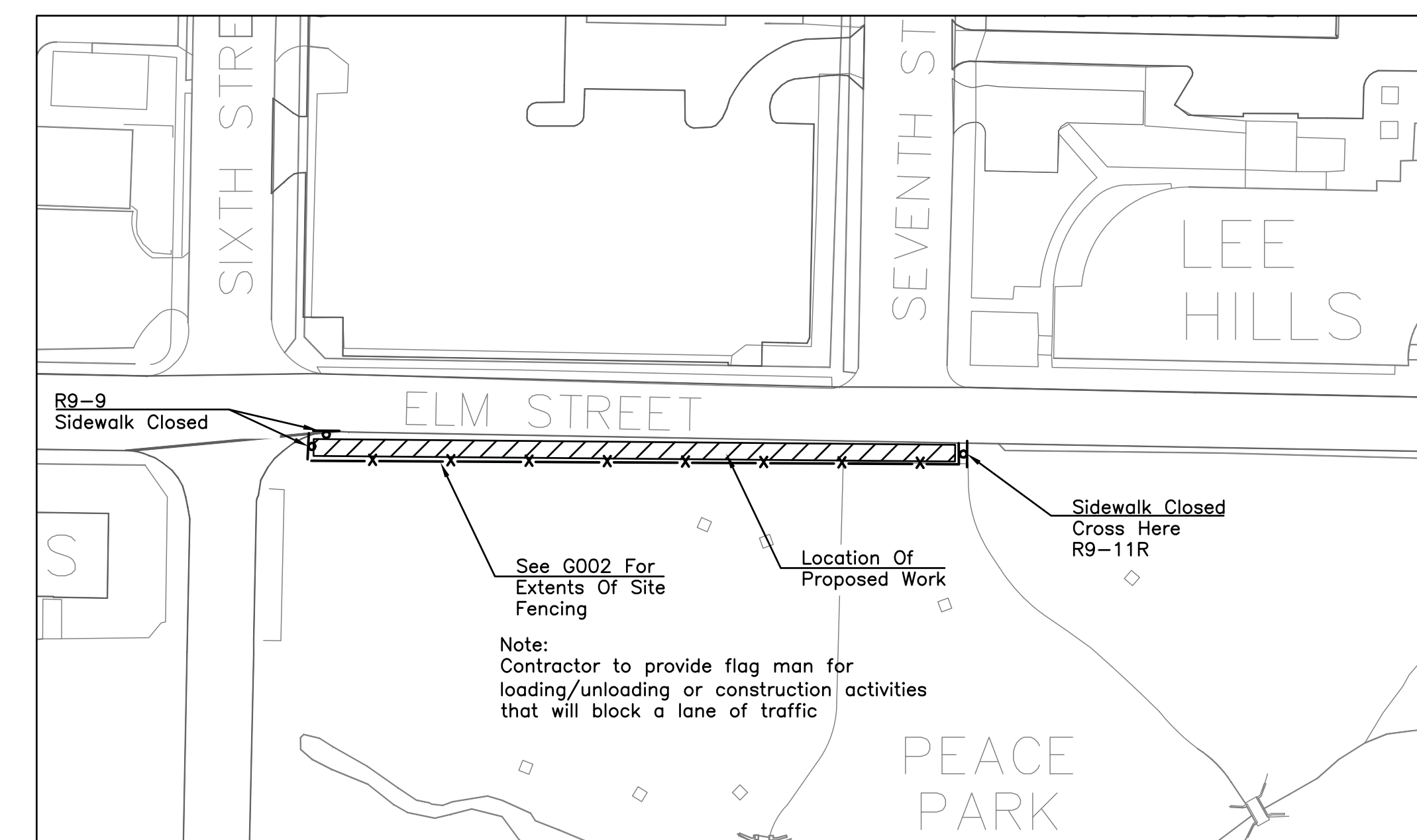
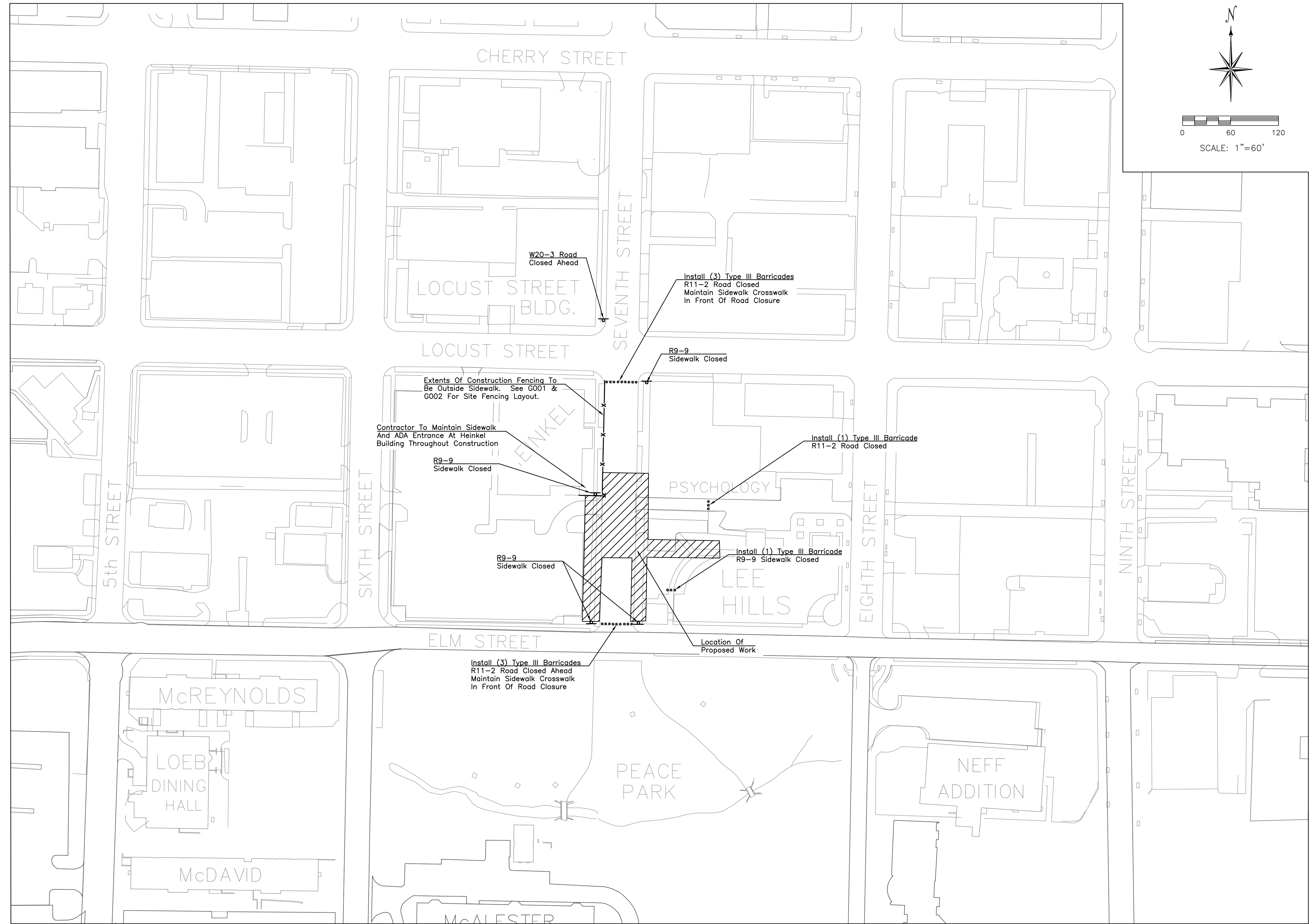

ADD ALTERNATE #1 TRAFFIC CONTROL PLAN

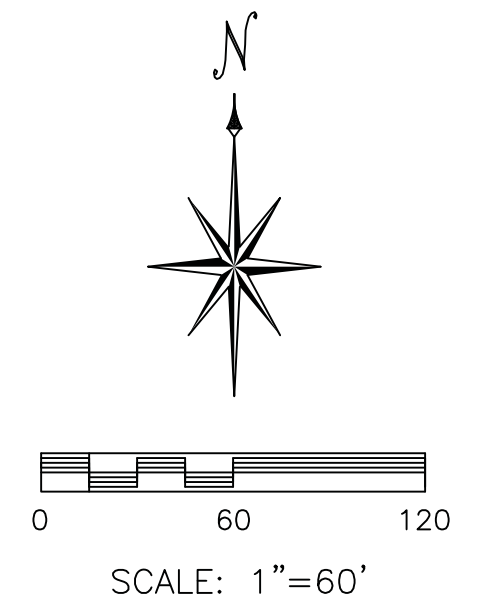

THIS MEDIA SHOULD NOT BE
 CONSIDERED A CERTIFIED
 DOCUMENT.

Keenan Simon
 MO-2016017682

The Professional Engineer, whose signature and personal seal appear on this document, certifies that the design, specification, calculation, report, document or drawings were prepared or checked by the Professional Engineer, or by a person registered under the supervision of the Professional Engineer, and that the Professional Engineer has the approval and seal of the Engineer on the design and specifications. The Professional Engineer shall be responsible for any errors or omissions in this document, which may result in any changes to the design or the Engineer's professional liability.

WHEN THIS DRAWING IS
 REPRODUCED AT ORIGINAL
 SCALE THIS BAR # 1 INCH



REVISIONS:

DATE	DESCRIPTION
11/17/2017	CONFORMANCE SET

DESIGNED BY: KKS
 CHECKED BY: RAF
 MU PROJ. NO.: CP170851
 SB PROJ. NO.: 505-108
 ISSUE DATE: 04/27/2017

DRAWING TITLE:
 TRAFFIC CONTROL PLAN

DRAWING NO.:

C003