

A STRIP OF LAND 15 FEET IN WIDTH LOCATED IN THE SOUTHEAST QUARTER OF SECTION 3, TOWNSHIP 48 NORTH, RANGE 12 WEST OF THE FIFTH PRINCIPAL MERIDIAN, COLUMBIA, MISSOURI, BEING PART OF THE LANDS DESCRIBED IN THE DEED RECORDED IN BOOK 2032, PAGE 878 OF THE RECORDS OF BOONE COUNTY, BEING FURTHER DESCRIBED AS FOLLOWS:

COMMENCING AT THE SOUTHEAST CORNER OF LOT 2 OF LAKEWOOD ESTATES, RECORDED IN PLAT BOOK 12 PAGE 5, OF SAID RECORDS; THENCE ALONG THE EAST LINE OF SAID LOT 2, N01°14'50"E, 34.07 FEET TO A POINT AT THE INTERSECTION OF THE NORTH RIGHT OF WAY LINE OF ST. CHARLES ROAD AND SAID EAST LINE, SAID POINT BEING THE POINT OF BEGINNING OF THE FOLLOWING DESCRIPTION;

THENCE LEAVING SAID RIGHT OF WAY LINE AND CONTINUING ALONG SAID EAST LINE, N01°14'50"E, 15.01 FEET; THENCE LEAVING SAID EAST LINE, S89°36'20"W, 34.91 FEET; THENCE S00°23'40"E, 15.00 FEET TO THE NORTH RIGHT OF WAY LINE OF ST. CHARLES ROAD; THENCE ALONG SAID NORTH RIGHT OF WAY LINE, N89°36'20"E, 34.48 FEET TO THE POINT OF BEGINNING.

THIS DOCUMENT HAS BEEN ELECTRONICALLY SIGNED, SEALED AND DATED.



Timothy J. Devaney
MO PLS-2024016357
November 19, 2024

OWNER: JOLLY, INC.
ADDRESS: 5701 E ST. CHARLES ROAD
PROJECT: CLARK LANE TO DEMARET STORM & SIDEWALK
PARCEL: 17-212-03-01-119.00 01
TYPE OF EASEMENT: TEMPORARY CONSTRUCTION EASEMENT

DRAWING PATH: P:\202300051704-Drawings\Survey\Easements\2023000517-000 ESMTS.dwg PLOT DATE: 11/19/2024 2:12 PM PLOTTED BY: CONNOR CARLETON



2001 W Broadway
Columbia, Missouri 65202
573-814-1568
www.mcclurevision.com
COA: 2012009395
EXPIRES: DEC. 31ST, 2024

TEMPORARY
CONSTRUCTION
EASEMENT EXHIBIT
COLUMBIA, MISSOURI
BOONE COUNTY
2023000517-000
11/15/2024

ENGINEER J.TUEY DRAWN BY C.COOPER
SURVEYOR T.DEVANNEY CREW CHIEF J.DIERKER

TEMPORARY CONSTRUCTION EASEMENT EXHIBIT

EXHIBIT A

LAKWOOD
ESTATES

LOT 2, LAKEWOOD ESTATES
OWNER: JOLLY, INC.
DEED: BK. 2032, PG. 878

SE 1/4
SEC. 3-T48N-R12W

EAST LINE LOT 2,
LAKEWOOD ESTATES

TEMPORARY CONSTRUCTION
EASEMENT AREA: 520 ± SQ. FT.

S00°23'40"E
15.00'

S89°36'20"W
34.91'

N01°14'50"E
15.01'

NORTH R/W LINE
ST. CHARLES ROAD

ST. CHARLES ROAD

N89°36'20"E
34.48'

POINT OF
BEGINNING

S. LINE SE 1/4
SEC.3-T48N-R12W

POINT OF COMMENCING
SE COR. LOT 2
LAKEWOOD ESTATES
DOC NO. 1025, BK. 12, PG. 5

N01°14'50"E
34.07'



NORTH

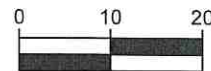

(IN FEET)
1 inch = 20 ft.

LEGEND	
	PROPERTY LINE
	SECTION LINE
	ROW LINE
	EASEMENT AREA

DRAWING PATH: P:\202300051704-Drawings\Survey\Easements\2023000517-000 ESMTS.dwg PLOT DATE: 11/19/2024 2:12 PM PLOTTED BY: CONNOR CARLETON



2001 W Broadway
Columbia, Missouri 65202
573-814-1568
www.mcclurevision.com
COA: 2012009395
EXPIRES: DEC. 31ST, 2024

TEMPORARY
CONSTRUCTION
EASEMENT EXHIBIT
COLUMBIA, MISSOURI
BOONE COUNTY
2023000517-000
11/15/2024

ENGINEER J.TUEY DRAWN BY C.COOPER
SURVEYOR T.DEVANAY CREW CHIEF J.DIERKER

PAGE #

PAGE 02 OF 02

A STRIP OF LAND 15 FEET IN WIDTH LOCATED IN THE SOUTHEAST QUARTER OF SECTION 3, TOWNSHIP 48 NORTH, RANGE 12 WEST OF THE FIFTH PRINCIPAL MERIDIAN, COLUMBIA, MISSOURI, BEING PART OF THE LANDS DESCRIBED IN THE DEED RECORDED IN BOOK 1241, PAGE 444 OF THE RECORDS OF BOONE COUNTY, BEING FURTHER DESCRIBED AS FOLLOWS:

COMMENCING AT THE SOUTHEAST CORNER OF SAID SECTION 3; THENCE ALONG THE SOUTH LINE OF THE SOUTHEAST QUARTER OF SAID SECTION, N88°57'10"W, 976.08 FEET TO THE EAST LINE OF THE TRACT DESCRIBED IN BOOK 1241, PAGE 444 OF SAID RECORDS; THENCE LEAVING SAID SOUTH LINE AND ALONG SAID EAST LINE, N01°14'50"E, 35.56 FEET TO A POINT AT THE INTERSECTION OF THE NORTH RIGHT OF WAY LINE OF ST. CHARLES ROAD AND SAID EAST LINE, SAID POINT BEING THE POINT OF BEGINNING OF THE FOLLOWING DESCRIPTION;

THENCE LEAVING SAID RIGHT OF WAY LINE AND CONTINUING ALONG SAID EAST LINE, N01°14'50"E, 15.01 FEET; THENCE LEAVING SAID EAST LINE, S89°34'10"W, 50.02 FEET TO THE WEST LINE OF SAID TRACT; THENCE ALONG THE WEST LINE OF SAID TRACT, S01°14'50"W, 15.01 FEET TO THE NORTH RIGHT OF WAY LINE OF ST. CHARLES ROAD; THENCE LEAVING SAID WEST LINE AND ALONG SAID NORTH RIGHT OF WAY LINE, N89°34'10"E, 50.02 FEET TO THE POINT OF BEGINNING.

THIS DOCUMENT HAS BEEN ELECTRONICALLY SIGNED, SEALED AND DATED.



Timothy J. Devaney
MO PLS-2024016357
November 20, 2024

OWNER: RDM DEVELOPMENT, LTD, A CORPORATION OF THE STATE OF MISSOURI
ADDRESS: 00000 ST. CHARLES ROAD
PROJECT: CLARK LANE TO DEMARET STORM & SIDEWALK
PARCEL: 17-212-00-00-001.00 01
TYPE OF EASEMENT: TEMPORARY CONSTRUCTION EASEMENT

DRAWING PATH: P:\2023000517\04-Drawings\Survey\Easements\2023000517-000 ESM\TS.dwg PLOT DATE: 11/20/2024 11:58 AM PLOTTED BY: CONNOR CARLETON



McCLURETM
making lives better.

2001 W Broadway
Columbia, Missouri 65202
573-814-1568
www.mcclurevision.com
COA: 2012009395
EXPIRES: DEC. 31ST, 2024

TEMPORARY
CONSTRUCTION
EASEMENT EXHIBIT
COLUMBIA, MISSOURI
BOONE COUNTY
2023000517-000
11/15/2024

ENGINEER J.TUEY	DRAWN BY C.COOPER
SURVEYOR T.DEVANEY	CREW CHIEF J.DIERKER
PAGE #	
PAGE 01 OF 02	

TEMPORARY CONSTRUCTION EASEMENT EXHIBIT

EXHIBIT A

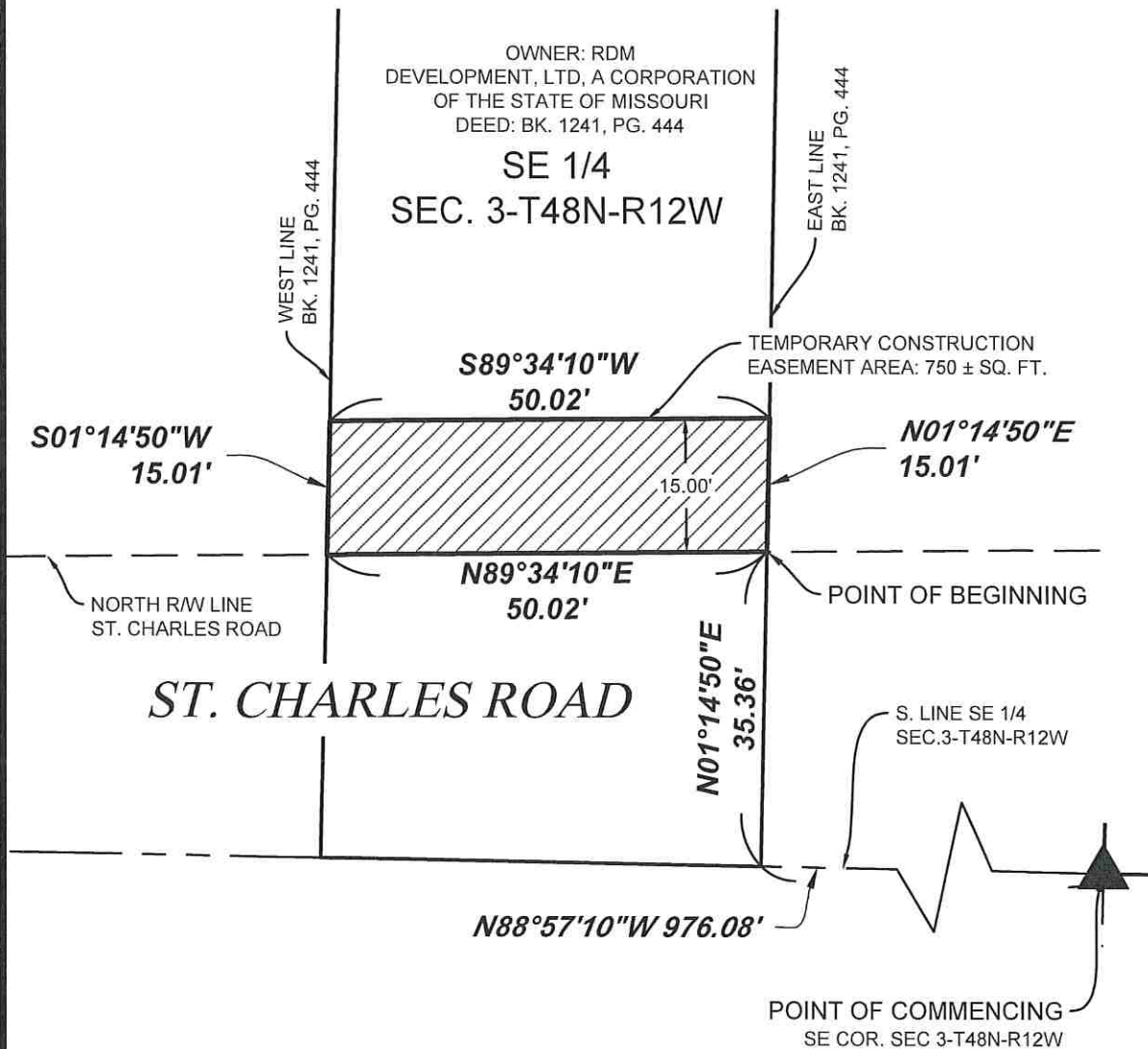

NORTH

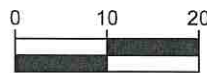

(IN FEET)
1 inch = 20 ft.

LEGEND	
	PROPERTY LINE
	SECTION LINE
	ROW LINE
	EASEMENT AREA

DRAWING PATH: P:\202300051704-Drawings\Survey\Easements\2023000517-000 ESMTS.dwg PLOT DATE: 11/20/2024 11:58 AM PLOTTED BY: CONNOR CARLETON



2001 W Broadway
Columbia, Missouri 65202
573-814-1568
www.mcclurevision.com
COA: 2012009395
EXPIRES: DEC. 31ST, 2024

TEMPORARY
CONSTRUCTION
EASEMENT EXHIBIT
COLUMBIA, MISSOURI
BOONE COUNTY
2023000517-000
11/15/2024

ENGINEER
J.TUEY
SURVEYOR
T.DEVANEY

DRAWN BY
C.COOPER
CREW CHIEF
J.DIERKER

PAGE #

PAGE 02 OF 02

A STRIP OF LAND 15 FEET IN WIDTH LOCATED IN SOUTHEAST QUARTER OF SECTION 3, TOWNSHIP 48 NORTH, RANGE 12 WEST OF THE FIFTH PRINCIPAL MERIDIAN, COLUMBIA, MISSOURI, BEING PART OF THE LANDS DESCRIBED IN THE DEED RECORDED IN BOOK 1652, PAGE 880 OF THE RECORDS OF BOONE COUNTY, BEING FURTHER DESCRIBED AS FOLLOWS:

COMMENCING AT THE SOUTHEAST CORNER OF SAID SECTION 3; THENCE ALONG THE SOUTH LINE OF THE SOUTHEAST QUARTER OF SAID SECTION, N88°57'10"W, 668.09 FEET TO THE EAST LINE OF THE TRACT DESCRIBED IN BOOK 1652, PAGE 880 OF SAID RECORDS; THENCE LEAVING SAID SOUTH LINE AND ALONG SAID EAST LINE, N01°02'50"E, 43.31 FEET TO A POINT AT THE INTERSECTION OF THE NORTH RIGHT OF WAY LINE OF ST. CHARLES ROAD AND SAID EAST LINE, SAID POINT BEING THE POINT OF BEGINNING OF THE FOLLOWING DESCRIPTION;

THENCE LEAVING SAID RIGHT OF WAY LINE AND CONTINUING ALONG SAID EAST LINE, N01°02'50"E, 15.01 FEET; THENCE LEAVING SAID EAST LINE, S89°34'10"W, 307.92 FEET TO THE WEST LINE OF SAID TRACT; THENCE ALONG THE WEST LINE OF SAID TRACT, S01°14'50"W, 15.01 FEET TO THE NORTH RIGHT OF WAY LINE OF ST. CHARLES ROAD; THENCE LEAVING SAID WEST LINE AND ALONG SAID NORTH RIGHT OF WAY LINE, N89°34'10"E, 307.97 FEET TO THE POINT OF BEGINNING.

THIS DOCUMENT HAS BEEN ELECTRONICALLY SIGNED, SEALED AND DATED.



Timothy J. Devaney
MO PLS-2024016357
November 20, 2024

OWNER: ROBYN ARMER
ADDRESS: 5717 ST. CHARLES ROAD
PROJECT: CLARK LANE TO DEMARET STORM & SIDEWALK
PARCEL: 17-212-00-00-002.00 01
TYPE OF EASEMENT: TEMPORARY CONSTRUCTION EASEMENT

DRAWING PATH: P:\2023000517\04-Drawings\Survey\Easements\2023000517-000 ESMTS.dwg PLOT DATE: 11/20/2024 11:40 AM PLOTTED BY: CONNOR CARLETON



2001 W Broadway
Columbia, Missouri 65202
573-814-1568
www.mcclurevision.com
COA: 2012009395
EXPIRES: DEC. 31ST, 2024

TEMPORARY
CONSTRUCTION
EASEMENT EXHIBIT
COLUMBIA, MISSOURI
BOONE COUNTY
2023000517-000
11/15/2024

ENGINEER J.TUEY DRAWN BY C.COOPER
SURVEYOR T.DEVANEY CREW CHIEF J.DIERKER

TEMPORARY CONSTRUCTION EASEMENT EXHIBIT

EXHIBIT A

OWNER: ROBYN ARMER
DEED: BK. 1652, PG. 880

SE 1/4
SEC. 3-T48N-R12W

WEST LINE
BK. 1652, PG. 880

EAST LINE
BK. 1652, PG. 880

$S01^{\circ}14'50''W$
15.01'

TEMPORARY CONSTRUCTION
EASEMENT AREA: 4,619 ± SQ. FT.

$S89^{\circ}34'10''W$ 307.92'

$N01^{\circ}02'50''E$
15.01'

NORTH R/W LINE
ST. CHARLES ROAD

$N89^{\circ}34'10''E$ 307.97'

$N01^{\circ}02'50''E$
43.31'

POINT OF
BEGINNING

ST. CHARLES ROAD

$N88^{\circ}57'10''W$ 668.09'

POINT OF COMMENCING
SE COR. SEC 3-T48N-R12W



NORTH

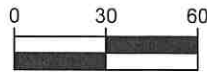

(IN FEET)
1 inch = 60 ft.

LEGEND	
	PROPERTY LINE
	SECTION LINE
	ROW LINE
	EASEMENT AREA

DRAWING PATH: P:\202300051704-Drawings\Survey\Easement\2023000517-000 ESM\T.dwg PLOT DATE: 11/20/2024 11:40 AM PLOTTED BY: CONNOR CARLETON



2001 W Broadway
Columbia, Missouri 65202
573-814-1568
www.mcclurevision.com
COA: 2012009395
EXPIRES: DEC. 31ST, 2024

TEMPORARY
CONSTRUCTION
EASEMENT EXHIBIT
COLUMBIA, MISSOURI
BOONE COUNTY
2023000517-000
11/15/2024

ENGINEER
J. TUEY
SURVEYOR
T. DEVANEY

DRAWN BY
C. COOPER
CREW CHIEF
J. DIERKER

PAGE #
PAGE 02 OF 02

A TRACT OF LAND LOCATED IN THE SOUTHEAST QUARTER OF SECTION 3, TOWNSHIP 48 NORTH, RANGE 12 WEST OF THE FIFTH PRINCIPAL MERIDIAN, COLUMBIA, MISSOURI, BEING PART OF THE LAND DESCRIBED IN THE DEED RECORDED IN BOOK 5319, PAGE 6, QUIT-CLAIM DEED RECORDED IN BOOK 3868, PAGE 55 AND TRUSTEE'S DEED RECORDED IN BOOK 3735, PAGE 173 OF THE RECORDS OF BOONE COUNTY, BEING FURTHER DESCRIBED AS FOLLOWS:

COMMENCING AT THE SOUTHEAST CORNER OF SAID SECTION 3; THENCE ALONG THE SOUTH LINE OF THE SOUTHEAST QUARTER OF SAID SECTION, N88°57'10"W, 468.09 FEET TO THE EAST LINE OF THE TRACT DESCRIBED IN BOOK 5319, PAGE 6 OF SAID RECORDS; THENCE LEAVING SAID SOUTH LINE AND ALONG SAID EAST LINE, N01°02'50"E, 48.54 FEET TO A POINT AT THE INTERSECTION OF THE NORTH RIGHT OF WAY LINE OF ST. CHARLES ROAD AND SAID EAST LINE, SAID POINT BEING THE POINT OF BEGINNING OF THE FOLLOWING DESCRIPTION;

THENCE LEAVING SAID RIGHT OF WAY LINE AND CONTINUING ALONG SAID EAST LINE, N01°02'50"E, 15.01 FEET; THENCE LEAVING SAID EAST LINE, S89°33'00"W, 134.19 FEET; THENCE N51°36'00"W, 23.92 FEET; THENCE S89°33'10"W, 18.44 FEET; THENCE S62°01'30"W, 32.48 FEET TO THE WEST LINE OF SAID TRACT; THENCE ALONG THE WEST LINE OF SAID TRACT, S01°02'50"W, 15.01 FEET TO THE NORTH RIGHT OF WAY LINE OF ST. CHARLES ROAD; THENCE LEAVING SAID WEST LINE AND ALONG SAID NORTH RIGHT OF WAY LINE, N89°33'00"E, 200.07 FEET TO THE POINT OF BEGINNING.

THIS DOCUMENT HAS BEEN ELECTRONICALLY SIGNED, SEALED AND DATED.



Timothy J. Devaney
MO PLS-2024016357
November 20, 2024

OWNER: JO ANN ALLEN, OR HER SUCCESSOR(S), TRUSTEE OF THE JO ANN ALLEN REVOCABLE TRUST U/T/A DATED MARCH 22, 2010

ADDRESS: 5813 ST. CHARLES ROAD

PROJECT: CLARK LANE TO DEMARET STORM & SIDEWALK

PARCEL: 17-212-00-00-003.00 01

TYPE OF EASEMENT: TEMPORARY CONSTRUCTION EASEMENT

DRAWING PATH: P:\2023000517\04-Drawings\Survey\Easements\2023000517-000 ESM\T.S.dwg PLOT DATE: 11/20/2024 11:41 AM PLOTTED BY: CONNOR CARLETON



2001 W Broadway
Columbia, Missouri 65202
573-814-1568
www.mcclurevision.com
COA: 2012009395
EXPIRES: DEC. 31ST, 2024

TEMPORARY
CONSTRUCTION
EASEMENT EXHIBIT
COLUMBIA, MISSOURI
BOONE COUNTY
2023000517-000
11/15/2024

ENGINEER J.TUEY DRAWN BY C.COOPER
SURVEYOR T.DEVANEY CREW CHIEF J.DIERKER

TEMPORARY CONSTRUCTION EASEMENT EXHIBIT

EXHIBIT A

OWNER: JO ANN ALLEN, OR HER SUCCESSOR(S),
 TRUSTEE OF THE JO ANN ALLEN REVOCABLE
 TRUST U/T/A DATED MARCH 22, 2010
 DEED: BK. 5319, PG. 6
 QUIT-CLAIM DEED: BK. 3868, PG. 55
 TRUSTEE'S DEED: BK. 3735, PG. 173

SE 1/4
 SEC. 3-T48N-R12W

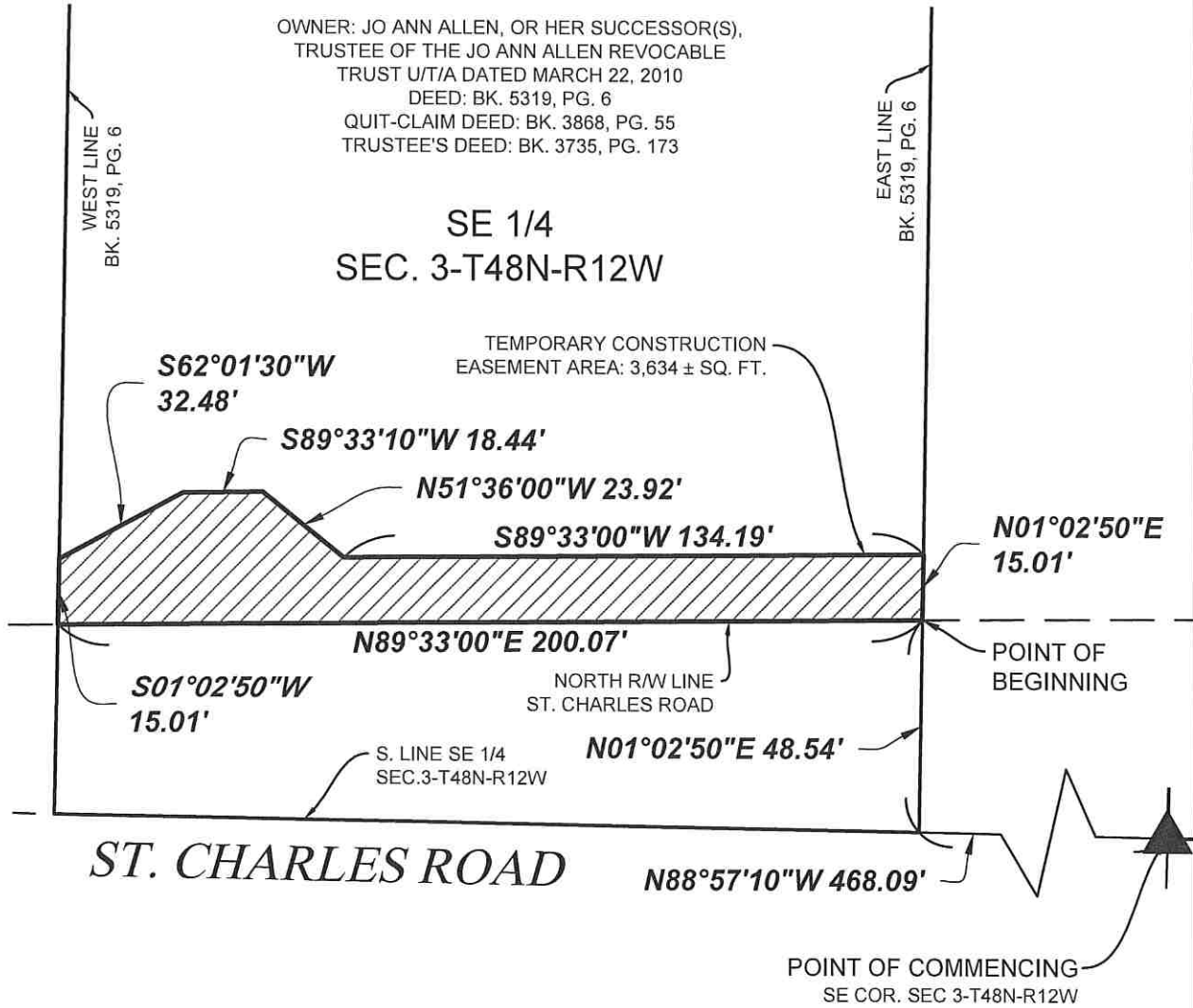

ST. CHARLES ROAD

N88°57'10\"W 468.09'



NORTH

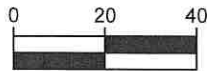

(IN FEET)
 1 inch = 40 ft.

LEGEND	
	PROPERTY LINE
	SECTION LINE
	ROW LINE
	EASEMENT AREA

DRAWING PATH: P:\2023000517\04-Drawings\Survey\Easements\2023000517-000 ESMTS.dwg PLOT DATE: 11/20/2024 11:41 AM PLOTTED BY: CONNOR CARLETON

McCLURETM
 making lives better.

201 W Broadway
 Columbia, Missouri 65202
 573-814-1568
 www.mcclurevision.com
 COA: 2012009395
 EXPIRES: DEC. 31ST, 2024

TEMPORARY
 CONSTRUCTION
 EASEMENT EXHIBIT
 COLUMBIA, MISSOURI
 BOONE COUNTY
 2023000517-000
 11/15/2024

ENGINEER
 J.TUEY
 SURVEYOR
 T.DEVANEY

DRAWN BY
 C.COOPER
 CREW CHIEF
 J.DIERKER

PAGE #

PAGE 02 OF 02

A TRACT OF LAND LOCATED IN THE SOUTHEAST QUARTER OF SECTION 3, TOWNSHIP 48 NORTH, RANGE 12 WEST OF THE FIFTH PRINCIPAL MERIDIAN, COLUMBIA, MISSOURI, BEING PART OF THE LANDS DESCRIBED IN THE DEED RECORDED IN BOOK 3303, PAGE 36 OF THE RECORDS OF BOONE COUNTY, BEING FURTHER DESCRIBED AS FOLLOWS:

COMMENCING AT THE SOUTHEAST CORNER OF SAID SECTION 3; THENCE ALONG THE SOUTH LINE OF THE SOUTHEAST QUARTER OF SAID SECTION, N88°57'10"W, 268.32 FEET TO THE EAST LINE OF THE WEST 200 FEET OF THE SURVEY RECORDED IN BOOK 289, PAGE 124; THENCE LEAVING SAID SOUTH LINE AND ALONG SAID EAST LINE, N01°15'10"E, 53.76 FEET TO A POINT AT THE INTERSECTION OF THE NORTH RIGHT OF WAY LINE OF ST. CHARLES ROAD AND SAID EAST LINE, SAID POINT BEING THE POINT OF BEGINNING OF THE FOLLOWING DESCRIPTION;

THENCE LEAVING SAID RIGHT OF WAY LINE AND CONTINUING ALONG SAID EAST LINE, N01°15'10"E, 15.01 FEET; THENCE LEAVING SAID EAST LINE, S89°33'10"W, 104.83 FEET; THENCE N57°28'00"W, 27.56 FEET; THENCE S89°33'10"W, 12.14 FEET; THENCE S56°31'30"W, 27.52 FEET; THENCE S89°33'10"W, 36.93 FEET TO THE WEST LINE OF SAID SURVEY; THENCE ALONG THE WEST LINE OF SAID SURVEY, S01°02'50"W, 15.01 FEET TO THE NORTH RIGHT OF WAY LINE OF ST. CHARLES ROAD; THENCE LEAVING SAID WEST LINE AND ALONG SAID NORTH RIGHT OF WAY LINE, N89°33'10"E, 200.03 FEET TO THE POINT OF BEGINNING.

THIS DOCUMENT HAS BEEN ELECTRONICALLY SIGNED, SEALED AND DATED.



Timothy J. Devaney
MO PLS-2024016357
November 18, 2024

OWNER: BRIAN J. PAINTER, A SINGLE PERSON
ADDRESS: 5905 ST. CHARLES RD
PROJECT: CLARK LANE TO DEMARET STORM & SIDEWALK
PARCEL: 17-212-00-00-004.00 01
TYPE OF EASEMENT: TEMPORARY CONSTRUCTION EASEMENT

DRAWING PATH: P:\2023000517\04-Drawings\Survey\Easements\2023000517-000 ESM\TS.dwg PLOT DATE: 11/19/2024 3:28 PM PLOTTED BY: CONNOR CARLETON



2001 W Broadway
Columbia, Missouri 65202
573-814-1568
www.mcclurevision.com
COA: 2012009395
EXPIRES: DEC. 31ST, 2024

TEMPORARY
CONSTRUCTION
EASEMENT EXHIBIT
COLUMBIA, MISSOURI
BOONE COUNTY
2023000517-000
11/15/2024

ENGINEER J.TUEY DRAWN BY C.COOPER
SURVEYOR T.DEVANEY CREW CHIEF J.DIERKER
PAGE #
PAGE 01 OF 02

TEMPORARY CONSTRUCTION EASEMENT EXHIBIT

EXHIBIT A

OWNER: BRIAN J. PAINTER, A SINGLE PERSON
DEED: BK. 3303, PG. 36

SE 1/4
SEC. 3-T48N-R12W

W. LINE OF SURVEY
RECORDED IN BK. 289, PG. 124

E. LINE OF WEST 200' OF SURVEY
RECORDED IN BK. 289, PG. 124

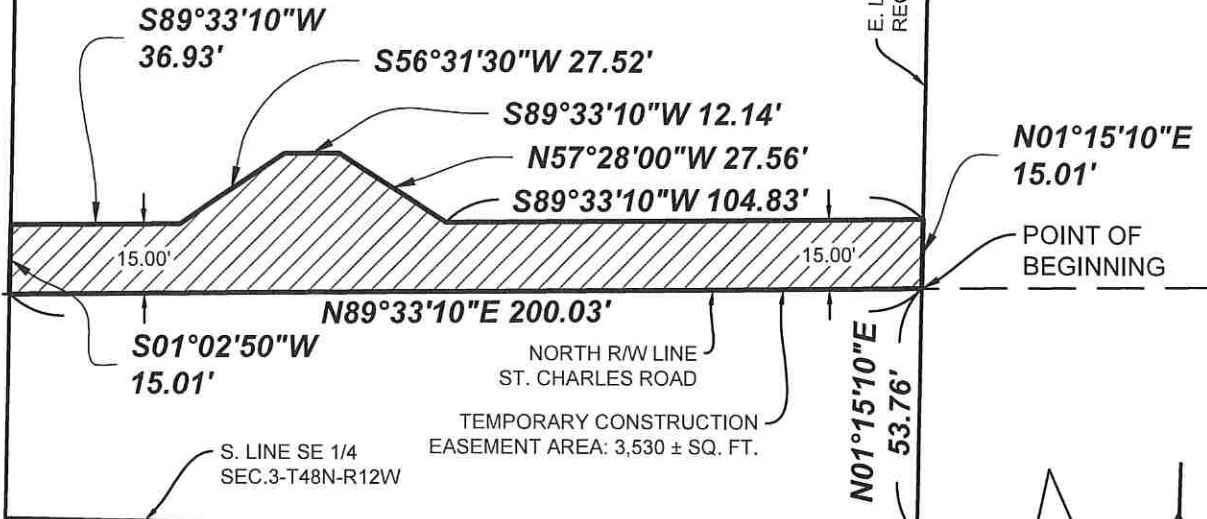

ST. CHARLES ROAD

N88°57'10\"W 268.32'

POINT OF COMMENCING
SE COR. SEC 3-T48N-R12W

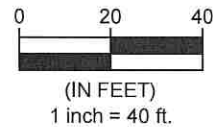

LEGEND	
	PROPERTY LINE
	SECTION LINE
	ROW LINE
	EASEMENT AREA

DRAWING PATH: P:\202300051704-Drawings\Survey\Easements\2023000517-000 ESMTS.dwg PLOT DATE: 11/18/2024 3:28 PM PLOTTED BY: CONNOR CARLETON



2001 W Broadway
Columbia, Missouri 65202
573-814-1568
www.mcclurevision.com
COA: 2012009395
EXPIRES: DEC. 31ST, 2024

TEMPORARY
CONSTRUCTION
EASEMENT EXHIBIT
COLUMBIA, MISSOURI
BOONE COUNTY
2023000517-000
11/15/2024

ENGINEER J.TUEY
SURVEYOR T.DEVANAY
DRAWN BY C.COOPER
CREW CHIEF J.DIERKER

PAGE #
PAGE 02 OF 02

A STRIP OF LAND 15 FEET IN WIDTH LOCATED IN THE SOUTHEAST QUARTER OF SECTION 3, TOWNSHIP 48 NORTH, RANGE 12 WEST OF THE FIFTH PRINCIPAL MERIDIAN, COLUMBIA, MISSOURI, BEING PART OF THE LANDS DESCRIBED IN THE DEED RECORDED IN BOOK 2799, PAGE 85 OF THE RECORDS OF BOONE COUNTY BEING FURTHER DESCRIBED AS FOLLOWS:

COMMENCING AT THE SOUTHEAST CORNER OF SAID SECTION 3; THENCE ALONG THE SOUTH LINE OF THE SOUTHEAST QUARTER OF SAID SECTION, N88°57'10"W, 191.65 FEET TO THE EAST LINE OF THE WEST 76 FEET 8 INCHES OF THE EAST 270 FEET OF THE SURVEY RECORDED IN BOOK 289, PAGE 124 OF SAID RECORDS; THENCE LEAVING SAID SOUTH LINE AND ALONG SAID EAST LINE, N01°15'10"E, 55.77 FEET TO A POINT AT THE INTERSECTION OF THE NORTH RIGHT OF WAY LINE OF ST. CHARLES ROAD AND SAID EAST LINE, SAID POINT BEING THE POINT OF BEGINNING OF THE FOLLOWING DESCRIPTION;

THENCE LEAVING SAID RIGHT OF WAY LINE AND CONTINUING ALONG SAID EAST LINE, N01°15'10"E, 15.01 FEET; THENCE LEAVING SAID EAST LINE, S89°32'50"W, 76.70 FEET TO THE WEST LINE OF SAID EAST 270 FEET OF SAID SURVEY; THENCE ALONG SAID WEST LINE, S01°15'10"W, 15.01 FEET TO THE NORTH RIGHT OF WAY LINE OF ST. CHARLES ROAD; THENCE LEAVING SAID WEST LINE AND ALONG SAID NORTH RIGHT OF WAY LINE, N89°32'50"E, 76.70 FEET TO THE POINT OF BEGINNING.

THIS DOCUMENT HAS BEEN ELECTRONICALLY SIGNED, SEALED AND DATED.



Timothy J. Devaney
MO PLS-2024016357
November 18, 2024

OWNER: JAMES ROSS NORMAN AND ELIZABETH JOAN PUCKETT, AS JOINT TENANTS WITH RIGHTS OF SURVIVORSHIP
ADDRESS: 5909 E ST. CHARLES RD
PROJECT: CLARK LANE TO DEMARET STORM & SIDEWALK
PARCEL: 17-212-03-00-012.00 01
TYPE OF EASEMENT: TEMPORARY CONSTRUCTION EASEMENT

DRAWING PATH: P:\2023000517\04-Drawings\Survey\Easements\2023000517-000 ESMTS.dwg PLOT DATE: 11/18/2024 3:29 PM PLOTTED BY: CONNOR CARLETON



2001 W Broadway
Columbia, Missouri 65202
573-814-1568
www.mcclurevision.com
COA: 2012009395
EXPIRES: DEC. 31ST, 2024

TEMPORARY
CONSTRUCTION
EASEMENT EXHIBIT
COLUMBIA, MISSOURI
BOONE COUNTY
2023000517-000
11/15/2024

ENGINEER J.TUEY DRAWN BY C.COOPER
SURVEYOR T.DEVANEY CREW CHIEF J.DIERKER

TEMPORARY CONSTRUCTION EASEMENT EXHIBIT EXHIBIT A

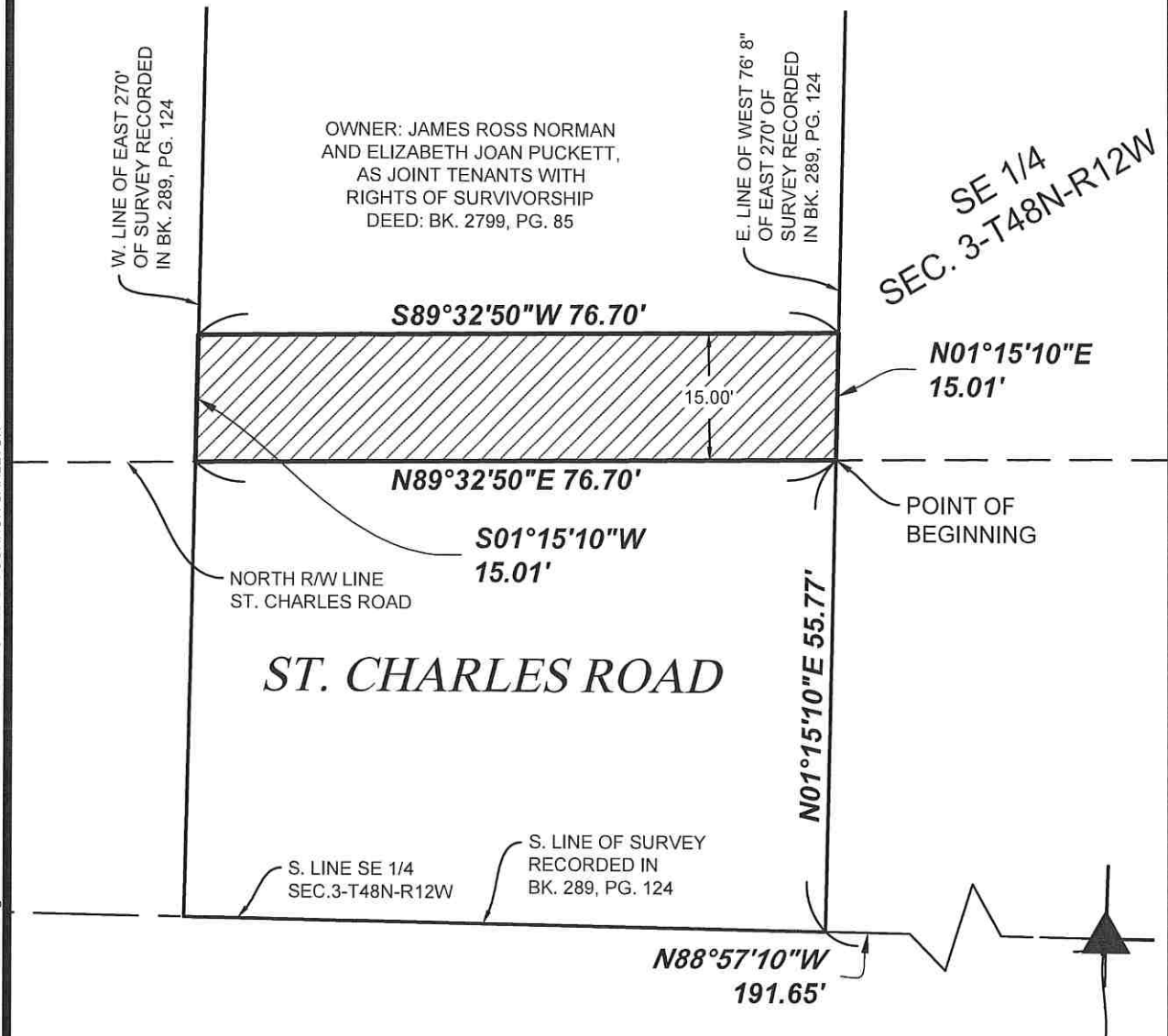

W. LINE OF EAST 270' OF SURVEY RECORDED IN BK. 289, PG. 124

OWNER: JAMES ROSS NORMAN AND ELIZABETH JOAN PUCKETT, AS JOINT TENANTS WITH RIGHTS OF SURVIVORSHIP DEED: BK. 2799, PG. 85

E. LINE OF WEST 76' 8\"/>

SE 1/4 SEC. 3-T48N-R12W

S89°32'50"W 76.70'

N01°15'10"E 15.01'

15.00'

N89°32'50"E 76.70'

POINT OF BEGINNING

S01°15'10"W 15.01'

NORTH R/W LINE ST. CHARLES ROAD

ST. CHARLES ROAD

N01°15'10"E 55.77'

S. LINE SE 1/4 SEC. 3-T48N-R12W

S. LINE OF SURVEY RECORDED IN BK. 289, PG. 124

N88°57'10"W 191.65'

POINT OF COMMENCING SE COR. SEC 3-T48N-R12W



NORTH

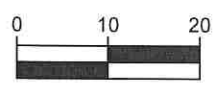

(IN FEET)
1 inch = 40 ft.

LEGEND	
	PROPERTY LINE
	SECTION LINE
	ROW LINE
	EASEMENT AREA

DRAWING PATH: P:\2023000517\04-Drawings\Survey\Easements\2023000517-000 ESM.TS.dwg PLOT DATE: 11/18/2024 3:29 PM PLOTTED BY: CONNOR CARLETON

201 W Broadway
Columbia, Missouri 65202
573-814-1568
www.mcclurevision.com
COA: 2012009395
EXPIRES: DEC. 31ST, 2024

TEMPORARY CONSTRUCTION EASEMENT EXHIBIT
COLUMBIA, MISSOURI
BOONE COUNTY
2023000517-000
11/15/2024

ENGINEER J.TUEY DRAWN BY C.COOPER
SURVEYOR T.DEVANEY CREW CHIEF J.DIERKER
PAGE #
PAGE 02 OF 02

A STRIP OF LAND 15 FEET IN WIDTH LOCATED IN THE SOUTHWEST QUARTER OF SECTION 2, TOWNSHIP 48 NORTH, RANGE 12 WEST OF THE FIFTH PRINCIPAL MERIDIAN, COLUMBIA, MISSOURI, BEING PART OF THE LANDS DESCRIBED IN THE DEED RECORDED IN BOOK 4540, PAGE 20 OF THE RECORDS OF BOONE COUNTY, BEING FURTHER DESCRIBED AS FOLLOWS:

COMMENCING AT THE SOUTHWEST CORNER OF SAID SECTION 2; THENCE ALONG THE SOUTH LINE OF THE SOUTHWEST QUARTER OF SAID SECTION, S89°23'10"E, 212.94 FEET TO THE WEST LINE OF TRACT "A" OF THE SURVEY RECORDED IN BOOK 379, PAGE 767 OF SAID RECORDS; THENCE LEAVING SAID SOUTH LINE AND ALONG SAID WEST LINE, N01°12'40"E, 64.82 FEET TO A POINT AT THE INTERSECTION OF THE NORTH RIGHT OF WAY LINE OF ST. CHARLES ROAD AND SAID WEST LINE, SAID POINT BEING THE POINT OF BEGINNING OF THE FOLLOWING DESCRIPTION;

THENCE LEAVING SAID RIGHT OF WAY LINE AND CONTINUING ALONG SAID WEST LINE, N01°12'40"E, 15.01 FEET; THENCE LEAVING SAID WEST LINE, S89°32'00"W, 81.07 FEET; THENCE S00°28'00"E, 15.00 FEET TO THE NORTH RIGHT OF WAY LINE OF ST. CHARLES ROAD; THENCE ALONG SAID NORTH RIGHT OF WAY LINE, N89°32'00"E, 80.63 FEET TO THE POINT OF BEGINNING.

THIS DOCUMENT HAS BEEN ELECTRONICALLY SIGNED, SEALED AND DATED.



Timothy J. Devaney
MO PLS-2024016357
November 19, 2024

OWNER: CURTIS S. BOCK AND JESSICA M. BOCK, HUSBAND AND WIFE
ADDRESS: 6003 E ST. CHARLES RD
PROJECT: CLARK LANE TO DEMARET STORM & SIDEWALK
PARCEL: 17-309-02-00-017.00 01
TYPE OF EASEMENT: TEMPORARY CONSTRUCTION EASEMENT

DRAWING PATH: P:\202300051704-Drawings\Survey\Easements\2023000517-000 ESMTS.dwg PLOT DATE: 11/19/2024 2:17 PM PLOTTED BY: CONNOR CARLETON



2001 W Broadway
Columbia, Missouri 65202
573-814-1568
www.mcclurevision.com
COA: 2012009395
EXPIRES: DEC. 31ST, 2024

TEMPORARY
CONSTRUCTION
EASEMENT EXHIBIT
COLUMBIA, MISSOURI
BOONE COUNTY
2023000517-000
11/15/2024

ENGINEER J.TUEY DRAWN BY C.COOPER
SURVEYOR T.DEVANEY CREW CHIEF J.DIERKER

TEMPORARY CONSTRUCTION EASEMENT EXHIBIT

EXHIBIT A

OWNER: CURTIS S. BOCK AND JESSICA
M. BOCK, HUSBAND AND WIFE
DEED: BK. 4540, PG. 20

SW 1/4
SEC. 2-T48N-R12W

W. LINE OF SURVEY RECORDED
FEBRUARY 6, 1969 IN BK. 379, PG. 767

LAKE OF THE WOODS ROAD

EASTERLY R/W LINE
LAKE OF THE WOODS ROAD

TEMPORARY CONSTRUCTION
EASEMENT AREA: 1,213 ± SQ. FT.

W. LINE OF TRACT "A" IN SURVEY RECORDED
FEBRUARY 6, 1969 IN BK. 379, PG. 767

S00°28'00"E 15.00'

S89°32'00"W
81.07'

N01°12'40"E
15.01'

NORTHERLY R/W LINE
ST. CHARLES ROAD

N89°32'00"E
80.63'

POINT OF
BEGINNING

N01°12'40"E
64.82'

ST. CHARLES ROAD

S89°23'10"E 212.94'

S. LINE SW 1/4
SEC. 2-T48N-R12W

POINT OF COMMENCING

SW COR. SW 1/4 SEC. 2-T48N-R12W
SW COR. SURVEY RECORDED FEBRUARY
6, 1969 IN BOOK 379, AT PAGE 767



NORTH

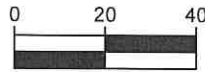

(IN FEET)
1 inch = 40 ft.

LEGEND	
	PROPERTY LINE
	SECTION LINE
	ROW LINE
	EASEMENT AREA

DRAWING PATH: P:\2023000517\04-Drawings\Survey\Easements\2023000517-000 ESMTS.dwg PLOT DATE: 11/19/2024 2:17 PM PLOTTED BY: CONNOR CARLETON



2001 W Broadway
Columbia, Missouri 65202
573-814-1568
www.mcclurevision.com
COA: 2012009395
EXPIRES: DEC. 31ST, 2024

TEMPORARY
CONSTRUCTION
EASEMENT EXHIBIT
COLUMBIA, MISSOURI
BOONE COUNTY
2023000517-000
11/15/2024

ENGINEER
J.TUEY
SURVEYOR
T.DEVANEY

DRAWN BY
C.COOPER
CREW CHIEF
J.DIERKER

PAGE #
PAGE 02 OF 02

A TRACT OF LAND LOCATED IN THE SOUTHWEST QUARTER OF SECTION 2, TOWNSHIP 48 NORTH, RANGE 12 WEST OF THE FIFTH PRINCIPAL MERIDIAN, COLUMBIA, MISSOURI, BEING PART OF THE LAND DESCRIBED IN THE DEED RECORDED IN BOOK 5380, PAGE 10 OF THE RECORDS OF BOONE COUNTY, BEING FURTHER DESCRIBED AS FOLLOWS:

COMMENCING AT THE SOUTHWEST CORNER OF SAID SECTION 2; THENCE ALONG THE SOUTH LINE OF THE SOUTHWEST QUARTER OF SAID SECTION, S89°23'10"E, 212.94 FEET TO THE WEST LINE OF TRACT "A" OF THE SURVEY RECORDED IN BOOK 379, PAGE 767 OF SAID RECORDS; THENCE LEAVING SAID SOUTH LINE AND ALONG SAID WEST LINE, N01°12'40"E, 64.82 FEET TO A POINT AT THE INTERSECTION OF THE NORTH RIGHT OF WAY LINE OF ST. CHARLES ROAD AND SAID WEST LINE, SAID POINT BEING THE POINT OF BEGINNING OF THE FOLLOWING DESCRIPTION;

THENCE LEAVING SAID RIGHT OF WAY LINE AND CONTINUING ALONG SAID WEST LINE, N01°12'40"E, 15.01 FEET; THENCE LEAVING SAID WEST LINE, N89°31'50"E, 98.14 FEET; THENCE N00°59'00"E, 17.13 FEET; THENCE N89°30'00"E, 113.58 FEET TO THE EAST LINE OF TRACT "B" OF SAID SURVEY; THENCE ALONG SAID EAST LINE, S00°59'00"W, 32.19 FEET TO THE NORTH RIGHT OF WAY LINE OF ST. CHARLES ROAD; THENCE LEAVING SAID EAST LINE AND ALONG SAID NORTH RIGHT OF WAY LINE, S89°31'50"W, 211.77 FEET TO THE POINT OF BEGINNING.

THIS DOCUMENT HAS BEEN ELECTRONICALLY SIGNED, SEALED AND DATED.



Timothy J. Devaney
MO PLS-2024016357
November 20, 2024

OWNER: CURTIS S. BOCK AND JESSICA M. BOCK, HUSBAND AND WIFE
ADDRESS: 6007 E ST. CHARLES RD
PROJECT: CLARK LANE TO DEMARET STORM & SIDEWALK
PARCEL: 17-309-02-00-018.00 01
TYPE OF EASEMENT: TEMPORARY CONSTRUCTION EASEMENT

DRAWING PATH: P:\2023000517\04-Drawings\Survey\Easements\2023000517-000 ESMTS.dwg PLOT DATE: 11/20/2024 11:40 AM PLOTTED BY: CONNOR CARLETON



2001 W Broadway
Columbia, Missouri 65202
573-814-1568
www.mcclurevision.com
COA: 2012009395
EXPIRES: DEC. 31ST, 2024

TEMPORARY
CONSTRUCTION
EASEMENT EXHIBIT
COLUMBIA, MISSOURI
BOONE COUNTY
2023000517-000
11/15/2024

ENGINEER J.TUEY DRAWN BY C.COOPER
SURVEYOR T.DEVANEY CREW CHIEF J.DIERKER

TEMPORARY CONSTRUCTION EASEMENT EXHIBIT

EXHIBIT A

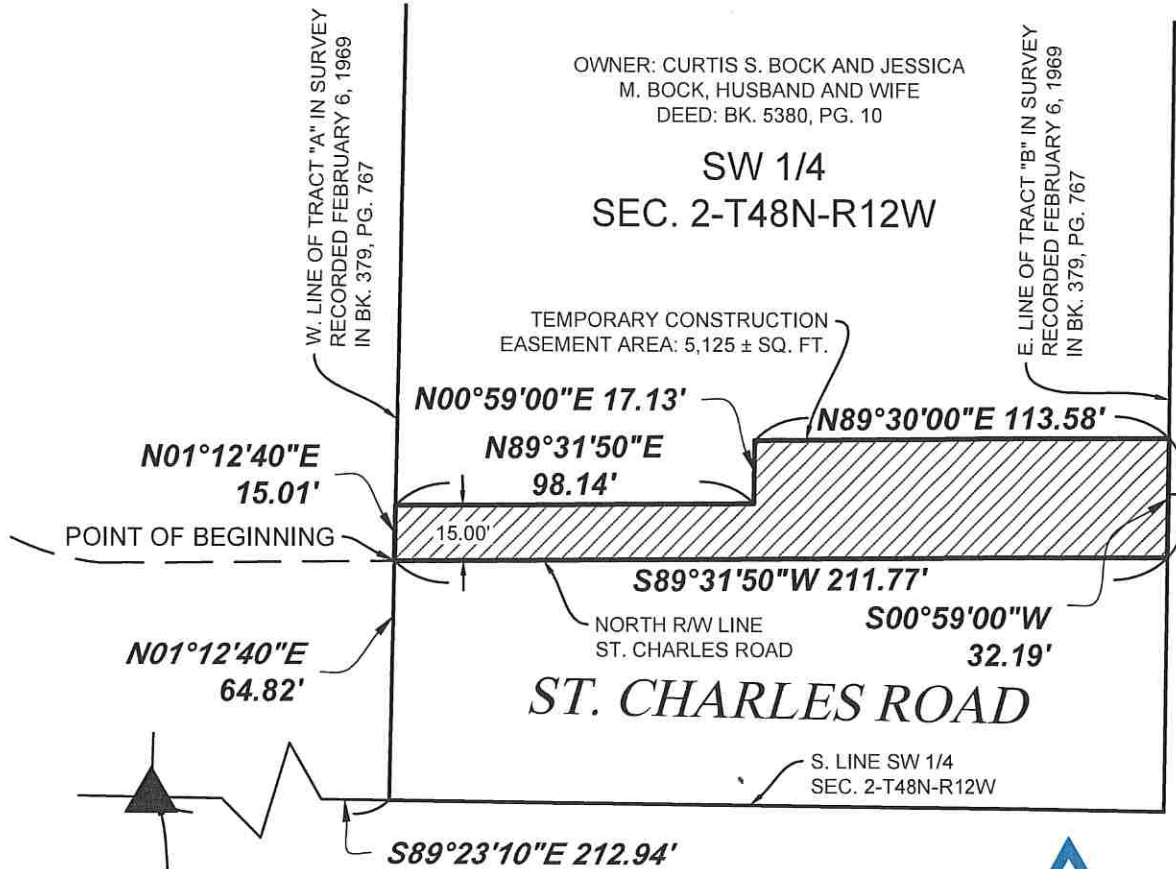

OWNER: CURTIS S. BOCK AND JESSICA
M. BOCK, HUSBAND AND WIFE
DEED: BK. 5380, PG. 10

SW 1/4
SEC. 2-T48N-R12W

TEMPORARY CONSTRUCTION
EASEMENT AREA: 5,125 ± SQ. FT.

POINT OF BEGINNING

POINT OF COMMENCING
SW COR. SEC 2-T48N-R12W

NORTH RW LINE
ST. CHARLES ROAD
ST. CHARLES ROAD

S. LINE SW 1/4
SEC. 2-T48N-R12W



NORTH

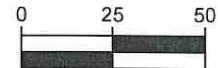

(IN FEET)

1 inch = 50 ft.

LEGEND	
	PROPERTY LINE
	SECTION LINE
	ROW LINE
	EASEMENT AREA

DRAWING PATH: P:\202300051704-Drawings\Survey\Easements\2023000517-000 ESMTS.dwg PLOT DATE: 11/20/2024 11:40 AM PLOTTED BY: CONNOR CARLETON



2001 W Broadway
Columbia, Missouri 65202
573-814-1568
www.mcclurevision.com
COA: 2012009395
EXPIRES: DEC. 31ST, 2024

TEMPORARY
CONSTRUCTION
EASEMENT EXHIBIT
COLUMBIA, MISSOURI
BOONE COUNTY
2023000517-000
11/15/2024

ENGINEER
J. TUEY
SURVEYOR
T. DEVANEY

DRAWN BY
C. COOPER
CREW CHIEF
J. DIERKER

PAGE #
PAGE 02 OF 02

A TRACT OF LAND LOCATED IN THE SOUTHWEST QUARTER OF SECTION 2, TOWNSHIP 48 NORTH, RANGE 12 WEST OF THE FIFTH PRINCIPAL MERIDIAN, COLUMBIA, MISSOURI, BEING PART OF THE LAND DESCRIBED IN THE DEEDS RECORDED IN BOOK 4835, PAGE 136 AND BOOK 3286, PAGE 49 OF THE RECORDS OF BOONE COUNTY, BEING FURTHER DESCRIBED AS FOLLOWS:

COMMENCING AT THE SOUTHEAST CORNER OF LOT 1 OF PIN OAKS SUBDIVISION, AS SHOWN IN PLAT BOOK 20, PAGE 9 OF SAID RECORDS; THENCE ALONG THE EAST LINE OF SAID LOT 1, N00°56'10"E, 21.50 FEET TO THE NORTH RIGHT OF WAY LINE OF ST. CHARLES ROAD; THENCE LEAVING SAID EAST LINE AND ALONG SAID RIGHT OF WAY ON A CURVE TO THE LEFT WITH A RADIUS OF 794.91 FEET FOR AN ARC LENGTH OF 67.81 FEET, THE CHORD BEARS N83°43'30"W, 67.79 FEET TO A POINT ON SAID RIGHT OF WAY, SAID POINT BEING THE POINT OF BEGINNING OF THE FOLLOWING DESCRIPTION;

THENCE CONTINUING ALONG SAID RIGHT OF WAY LINE AND SAID CURVE TO THE LEFT FOR AN ARC LENGTH OF 37.13 FEET, THE CHORD BEARS N87°30'30"W, 37.13 FEET; THENCE S88°49'00"W, 58.96 FEET TO THE EAST RIGHT OF WAY LINE OF PIN OAKS BOULEVARD; THENCE LEAVING THE NORTH RIGHT OF WAY LINE OF ST. CHARLES ROAD AND ALONG THE EAST RIGHT OF WAY OF PIN OAKS BOULEVARD, N00°30'10"E, 10.00 FEET; THENCE LEAVING THE EAST RIGHT OF WAY OF PIN OAKS BOULEVARD, N88°49'00"E, 55.56 FEET; THENCE S83°20'10"E, 40.68 FEET; THENCE S00°03'30"E, 6.83 FEET TO THE NORTH RIGHT OF WAY LINE OF ST. CHARLES ROAD AND THE POINT OF BEGINNING.

THIS DOCUMENT HAS BEEN ELECTRONICALLY SIGNED, SEALED AND DATED.



Timothy J. Devaney
MO PLS-2024016357
November 20, 2024

OWNER: EVERETT T WEST, TRUSTEE OF THE EVERETT T. WEST REVOCABLE TRUST DATED DECEMBER 7, 2017
ADDRESS: 1304 N PIN OAK BLVD
PROJECT: CLARK LANE TO DEMARET STORM & SIDEWALK
PARCEL: 17-309-02-01-007.00 01
TYPE OF EASEMENT: TEMPORARY CONSTRUCTION EASEMENT

DRAWING PATH: P:\2023000517\04-Drawings\Survey\Easements\2023000517-000 ESM\T.S.dwg PLOT DATE: 11/20/2024 11:39 AM PLOTTED BY: CONNOR CARLETON



2001 W Broadway
Columbia, Missouri 65202
573-814-1568
www.mcclurevision.com
COA: 2012009395
EXPIRES: DEC. 31ST, 2024

TEMPORARY
CONSTRUCTION
EASEMENT EXHIBIT
COLUMBIA, MISSOURI
BOONE COUNTY
2023000517-000
11/15/2024

ENGINEER J.TUEY DRAWN BY C.COOPER
SURVEYOR T.DEVANEY CREW CHIEF J.DIERKER

TEMPORARY CONSTRUCTION EASEMENT EXHIBIT

EXHIBIT A

PIN OAK BOULEVARD

PIN OAK
SUBDIVISION
BLOCK III

LOT 1, PIN OAKS SUBDIVISION, BLOCK III
OWNER: EVERETT T WEST,
TRUSTEE OF THE EVERETT T.
WEST REVOCABLE TRUST
DATED DECEMBER 7, 2017

DEED: BK. 4835, PG. 136 &
BK. 3286, PG. 49

SW 1/4
SEC. 2-T48N-R12W

TEMPORARY CONSTRUCTION
EASEMENT AREA: 887 ± SQ. FT.

E. LINE LOT 1, PIN OAKS
SUBDIVISION, BLOCK III

N. LINE R/W ST. CHARLES
ROAD TAKEN BY
CONDEMNATION CASE
NO. 99CC081023

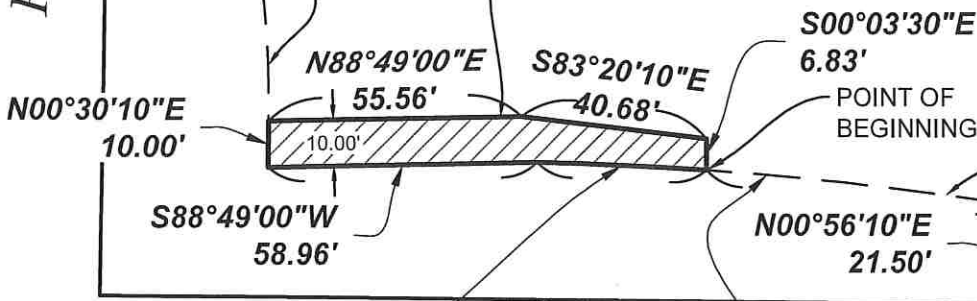

$L=37.13'$
 $R=794.91'$
 $CHD L=37.13'$
 $CHD=N87°30'30\"W$

S. LINE LOT 1, PIN OAKS
SUBDIVISION, BLOCK III

$L=67.81'$
 $R=794.91'$
 $CHD L=67.79'$
 $CHD=N83°43'30\"W$

ST. CHARLES ROAD

POINT OF COMMENCING
SE COR. LOT 1, PIN OAKS SUBDIVISION,
BLOCK III, RECORDED IN BK. 20, PG. 9

LEGEND	
	PROPERTY LINE
	SECTION LINE
	ROW LINE
	EASEMENT AREA



NORTH

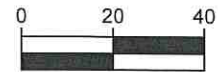

(IN FEET)
1 inch = 40 ft.

DRAWING PATH: P:\2023000517\04-Drawings\Survey\Easements\2023000517-000 ESMT'S.dwg PLOT DATE: 11/20/2024 11:39 AM PLOTTED BY: CONNOR CARLETON

McCLURETM
making lives better.

2001 W Broadway
Columbia, Missouri 65202
573-814-1568
www.mcclurevision.com
COA: 2012009395
EXPIRES: DEC. 31ST, 2024

TEMPORARY
CONSTRUCTION
EASEMENT EXHIBIT
COLUMBIA, MISSOURI
BOONE COUNTY
2023000517-000
11/15/2024

ENGINEER J. TUEY
SURVEYOR T. DEVANEY
DRAWN BY C. COOPER
CREW CHIEF J. DIERKER

PAGE #
PAGE 02 OF 02

A STRIP OF LAND 7.57 FEET IN WIDTH LOCATED IN THE SOUTHWEST QUARTER OF SECTION 2, TOWNSHIP 48 NORTH, RANGE 12 WEST OF THE FIFTH PRINCIPAL MERIDIAN, COLUMBIA, MISSOURI, BEING PART OF THE LAND DESCRIBED IN THE DEED RECORDED IN BOOK 4465, PAGE 159 OF THE RECORDS OF BOONE COUNTY, BEING FURTHER DESCRIBED AS FOLLOWS:

COMMENCING AT THE SOUTHEAST CORNER OF LOT 38 OF THE SURVEY RECORDED IN BOOK 374, PAGE 831 OF SAID RECORDS; THENCE ALONG THE EAST LINE OF SAID LOT 38, N00°02'20"W, 7.43 FEET TO A POINT AT THE INTERSECTION OF THE NORTH RIGHT OF WAY LINE OF ST. CHARLES ROAD AND SAID EAST LINE, SAID POINT BEING THE POINT OF BEGINNING OF THE FOLLOWING DESCRIPTION;

THENCE LEAVING SAID RIGHT OF WAY LINE AND CONTINUING ALONG SAID EAST LINE, N00°02'20"W, 7.57 FEET; THENCE LEAVING SAID EAST LINE, N89°33'30"W, 91.53 FEET; THENCE S00°26'30"W, 7.08 FEET TO THE NORTH RIGHT OF WAY LINE OF ST. CHARLES ROAD; THENCE ALONG SAID NORTH RIGHT OF WAY LINE ON A NON-TANGENT CURVE TO THE LEFT WITH A RADIUS OF 751.00 FEET FOR AN ARC LENGTH OF 27.32 FEET, THE CHORD BEARS S88°31'00"E, 27.32 FEET; THENCE CONTINUING ON SAID RIGHT OF WAY, S89°33'30"E, 64.28 FEET TO THE POINT OF BEGINNING.

THIS DOCUMENT HAS BEEN ELECTRONICALLY SIGNED, SEALED AND DATED.



Timothy J. Devaney
MO PLS-2024016357
November 20, 2024

OWNER: VOMUND RENTALS LLC
ADDRESS: 1305 N GOLF BLVD
PROJECT: CLARK LANE TO DEMARET STORM & SIDEWALK
PARCEL: 17-309-02-00-044.00 01
TYPE OF EASEMENT: TEMPORARY CONSTRUCTION EASEMENT

DRAWING PATH: P:\2023000517\04-Drawings\Survey\Easements\2023000517-000 ESM\TS.dwg PLOT DATE: 11/20/2024 11:37 AM PLOTTED BY: CONNOR CARLETON



2001 W Broadway
Columbia, Missouri 65202
573-814-1568
www.mcclurevision.com
COA: 2012009395
EXPIRES: DEC. 31ST, 2024

TEMPORARY
CONSTRUCTION
EASEMENT EXHIBIT
COLUMBIA, MISSOURI
BOONE COUNTY
2023000517-000
11/15/2024

ENGINEER J.TUEY DRAWN BY C.COOPER
SURVEYOR T.DEVANEY CREW CHIEF J.DIERKER

TEMPORARY CONSTRUCTION EASEMENT EXHIBIT

EXHIBIT A

OWNER: VOMUND RENTALS LLC
DEED: BK. 4465, PG. 159

SW 1/4
SEC. 2-T48N-R12W

E. LINE LOT 38, SURVEY RECORDED
IN BOOK 374 AT PAGE 831

NORTH RIGHT OF WAY LINE
ST. CHARLES ROAD
DOC NO. 3817, BOOK 1602, PAGE 432

S00°26'30"W
7.08'

TEMPORARY CONSTRUCTION
EASEMENT AREA: 689 ± SQ. FT.

N00°02'20"W
7.57'

N89°33'30"W 91.53'

7.57'

7.57'

POINT OF
BEGINNING

S89°33'30"E 64.28'

L=27.32' R=751.00'
CHD L=27.32'
CHD=S88°31'00"E

ST. CHARLES ROAD

SOUTH LINE LOT 38, SURVEY
RECORDED IN BOOK 374 AT PAGE 831

POINT OF COMMENCING
SE COR. LOT 38, SURVEY RECORDED
IN BOOK 374 AT PAGE 831

N00°02'20"W
7.43'



NORTH

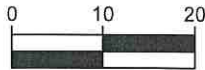

(IN FEET)
1 inch = 20 ft.

LEGEND	
	PROPERTY LINE
	SECTION LINE
	ROW LINE
	EASEMENT AREA



2001 W Broadway
Columbia, Missouri 65202
573-814-1568
www.mcclurevision.com
COA: 2012009395
EXPIRES: DEC. 31ST, 2024

TEMPORARY
CONSTRUCTION
EASEMENT EXHIBIT
COLUMBIA, MISSOURI
BOONE COUNTY
2023000517-000
11/15/2024

ENGINEER J.TUEY
SURVEYOR T.DEVANEY
DRAWN BY C.COOPER
CREW CHIEF J.DIERKER
PAGE #
PAGE 02 OF 02

DRAWING PATH: P:\202300051704-Drawings\Survey\Easements\2023000517-000 ESMTS.dwg PLOT DATE: 11/20/2024 11:37 AM PLOTTED BY: CONNOR CARLETON

A STRIP OF LAND 4.0 FEET IN WIDTH LOCATED IN THE SOUTHWEST QUARTER OF SECTION 2, TOWNSHIP 48 NORTH, RANGE 12 WEST OF THE FIFTH PRINCIPAL MERIDIAN, COLUMBIA, MISSOURI, BEING PART OF THE LAND DESCRIBED IN THE DEED RECORDED IN BOOK 4789, PAGE 28 OF THE RECORDS OF BOONE COUNTY, BEING FURTHER DESCRIBED AS FOLLOWS:

COMMENCING AT THE SOUTHEAST CORNER OF TRACT 3 OF THE SURVEY RECORDED IN BOOK 392, PAGE 644 OF SAID RECORDS; THENCE ALONG THE EAST LINE OF SAID TRACT 3, N00°39'50"E, 7.43 FEET TO A POINT AT THE INTERSECTION OF THE NORTH RIGHT OF WAY LINE OF ST. CHARLES ROAD AND SAID EAST LINE, SAID POINT BEING THE POINT OF BEGINNING OF THE FOLLOWING DESCRIPTION;

THENCE LEAVING SAID RIGHT OF WAY LINE AND CONTINUING ALONG SAID EAST LINE, N00°39'50"E, 4.00 FEET; THENCE LEAVING SAID EAST LINE, N89°18'10"W, 202.83 FEET TO THE WEST LINE OF TRACT 2 OF SAID SURVEY; THENCE ALONG SAID WEST LINE, S00°03'10"E, 4.00 FEET TO THE NORTH RIGHT OF WAY LINE OF ST. CHARLES ROAD; THENCE LEAVING SAID WEST LINE AND ALONG SAID NORTH RIGHT OF WAY LINE, S89°18'10"E, 202.78 FEET TO THE POINT OF BEGINNING.

THIS DOCUMENT HAS BEEN ELECTRONICALLY SIGNED, SEALED AND DATED.

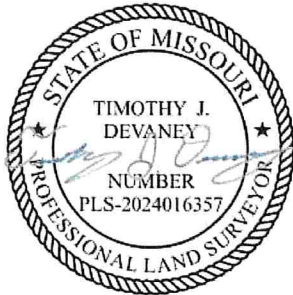

Timothy J. Devaney
MO PLS-2024016357
November 18, 2024

OWNER: MARK ROLAND MARTIN AND DONNA SUE MARTIN, HUSBAND AND WIFE
ADDRESS: 1300 N GOLF BLVD
PROJECT: CLARK LANE TO DEMARET STORM & SIDEWALK
PARCEL: 17-309-02-00-045.00 01
TYPE OF EASEMENT: TEMPORARY CONSTRUCTION EASEMENT

DRAWING PATH: P:\202300051704-Drawings\Survey\Easements\2023000517-000 ESMTS.dwg PLOT DATE: 11/18/2024 3:31 PM PLOTTED BY: CONNOR CARLETON



2001 W Broadway
Columbia, Missouri 65202
573-814-1568
www.mcclurevision.com
COA: 2012009395
EXPIRES: DEC. 31ST, 2024

TEMPORARY
CONSTRUCTION
EASEMENT EXHIBIT
COLUMBIA, MISSOURI
BOONE COUNTY
2023000517-000
11/15/2024

ENGINEER J.TUEY DRAWN BY C.COOPER
SURVEYOR T.DEVANEY CREW CHIEF J.DIERKER

TEMPORARY CONSTRUCTION EASEMENT EXHIBIT

EXHIBIT A

GOLF BOULEVARD

E. R/W LINE OF GOLF BOULEVARD

W. LINE TRACT 2 OF A SURVEY RECORDED IN BOOK 392, PAGE 644

OWNER: MARK ROLAND MARTIN AND DONNA SUE MARTIN, HUSBAND AND WIFE
DEED: BK. 4789, PG. 28

SW 1/4
SEC. 2-T48N-R12W

E. LINE TRACT 3 OF A SURVEY RECORDED IN BOOK 392, PAGE 644

S00°03'10"E
4.00'

N00°39'50"E
4.00'

POINT OF BEGINNING

4.00'

N89°18'10"W 202.83'

4.00'

S89°18'10"E 202.78'

NORTH RIGHT OF WAY LINE
ST. CHARLES ROAD
BOOK 1602, PAGE 434

POINT OF COMMENCING
SE COR. TRACT 3, OF A SURVEY
RECORDED IN BOOK 392, PAGE 644

SE COR. TRACT 2, OF A SURVEY RECORDED IN BOOK 392, PAGE 644

N00°39'50"E
7.43'

ST. CHARLES ROAD

S. LINE SW 1/4
SEC. 2-T48N-R12W



NORTH

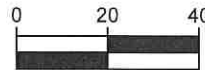

(IN FEET)
1 inch = 40 ft.

LEGEND	
	PROPERTY LINE
	SECTION LINE
	ROW LINE
	EASEMENT AREA

DRAWING PATH: P:\202300051704-Drawings\Survey\Easements\2023000517-000 ESMTS.dwg PLOT DATE: 11/18/2024 3:31 PM PLOTTED BY: CONNOR CARLETON



201 W Broadway
Columbia, Missouri 65202
573-814-1568
www.mcclurevision.com
COA: 2012009395
EXPIRES: DEC. 31ST, 2024

TEMPORARY
CONSTRUCTION
EASEMENT EXHIBIT
COLUMBIA, MISSOURI
BOONE COUNTY
2023000517-000
11/15/2024

ENGINEER J.TUEY
SURVEYOR T.DEVANNEY
DRAWN BY C.COOPER
CREW CHIEF J.DIERKER

PAGE #
PAGE 02 OF 02